

Projekt: **Sankt Augustin**

Verkehrszählung vom:
in der Zeit von:

24.06.2015
7-9; 15-19 Uhr

Auswertung des Zählstandortes

Nr.

1

Lage Meindorfer Straße / Am Bahnhof

Zählung erfolgte an: Knoten - 3-armig

Richtungsangaben

Straßennamen

- A Meindorfer Straße - L 16 West
- B Am Bahnhof
- D Meindorfer Straße - L 16 Ost

Kommentar

Nur Radverkehr auf Fahrbahn bzw. Schutzstreifen.

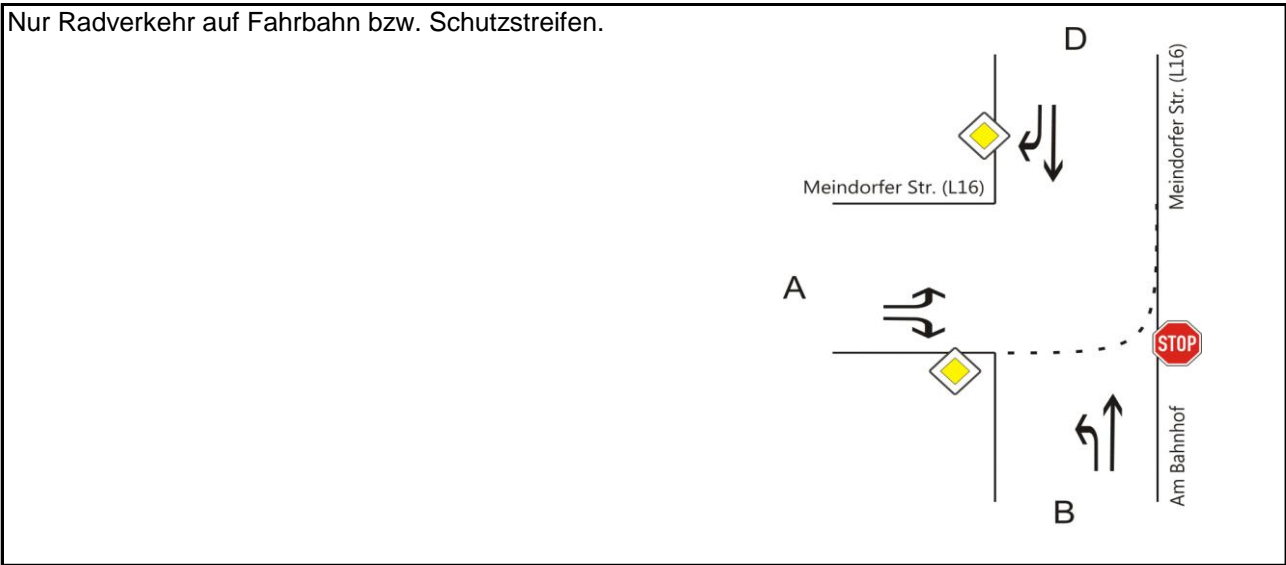

Σ der Ströme morgens 7:00 - 8:00 Uhr (Spitzenstunde)

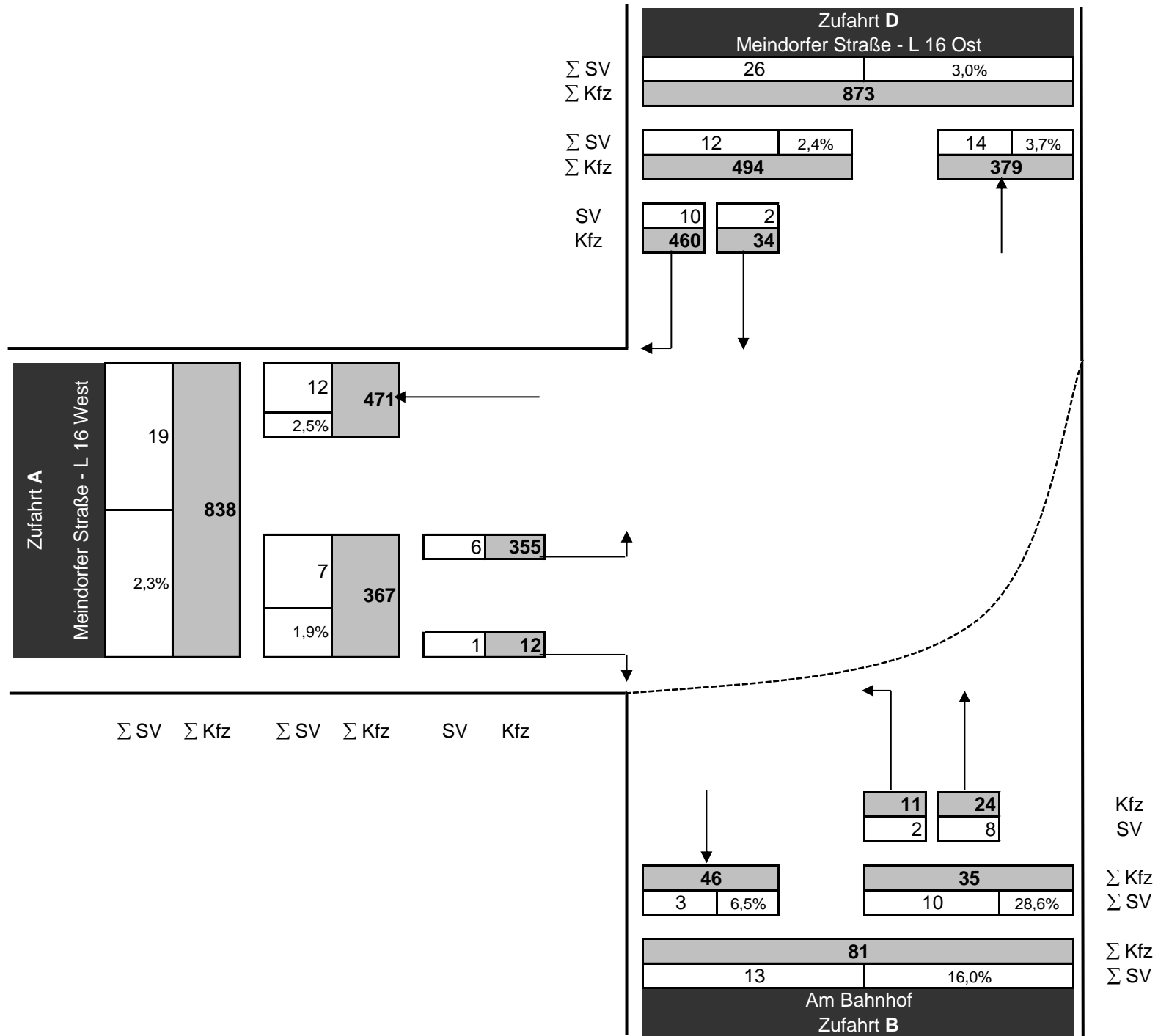

Verkehrsfluss - Diagramm als Kreuzung

Datei : SANKTAUGUSTIN_MENDEN2015_AMBAHNHOF_VM.kob
Projekt : Sankt-Augustin - GE Menden Süd 2015
Knoten : Meindorfer Straße / Am Bahnhof
Stunde : 7-8 Uhr

PKW-Einheiten

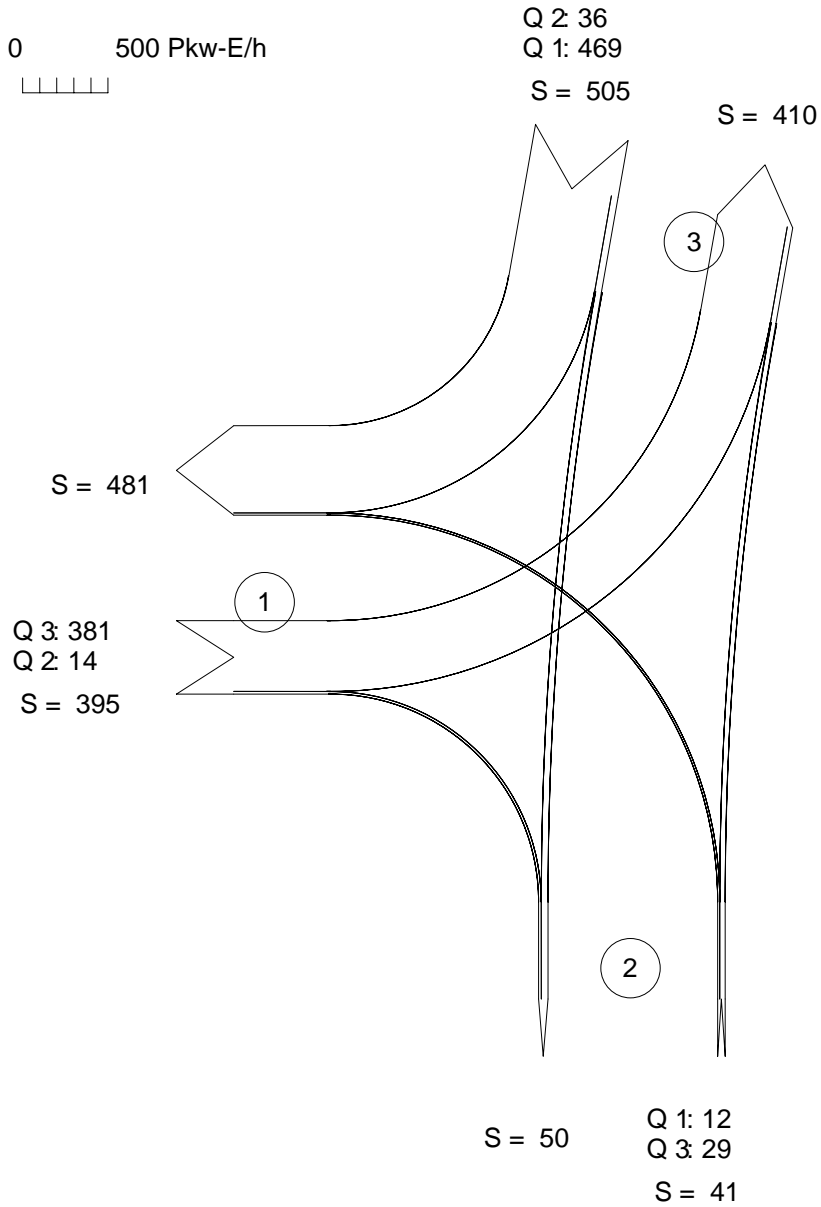

Summe = 941

Zufahrt 1: Meindorfer Straße - L16 / West
Zufahrt 2: Am Bahnhof
Zufahrt 3: Meindorfer Straße - L16 / Ost

Verkehrsfluss - Diagramm als Kreuzung

Datei : SANKTAUGUSTIN_MENDEN2015_AMBAHNHOF_VM.kob
 Projekt : Sankt-Augustin - GE Menden Süd 2015
 Knoten : Meindorfer Straße / Am Bahnhof
 Stunde : 7-8 Uhr

Kraftfahrzeuge

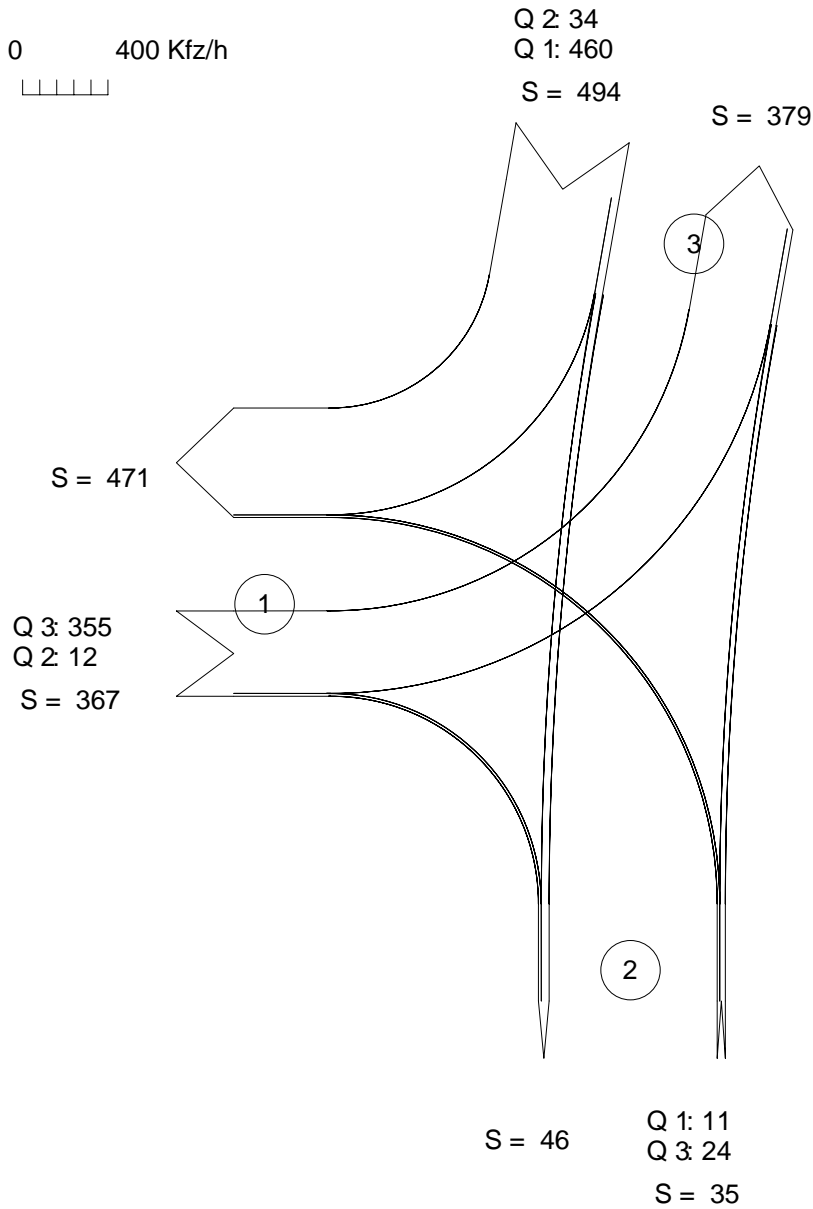

Summe = 896

Zufahrt 1: Meindorfer Straße - L16 / West
 Zufahrt 2: Am Bahnhof
 Zufahrt 3: Meindorfer Straße - L16 / Ost

Verkehrsfluss - Diagramm als Kreuzung

Datei : SANKTAUGUSTIN_MENDEN2015_AMBAHNHOF_VM.kob
 Projekt : Sankt-Augustin - GE Menden Süd 2015
 Knoten : Meindorfer Straße / Am Bahnhof
 Stunde : 7-8 Uhr

Fahrrad

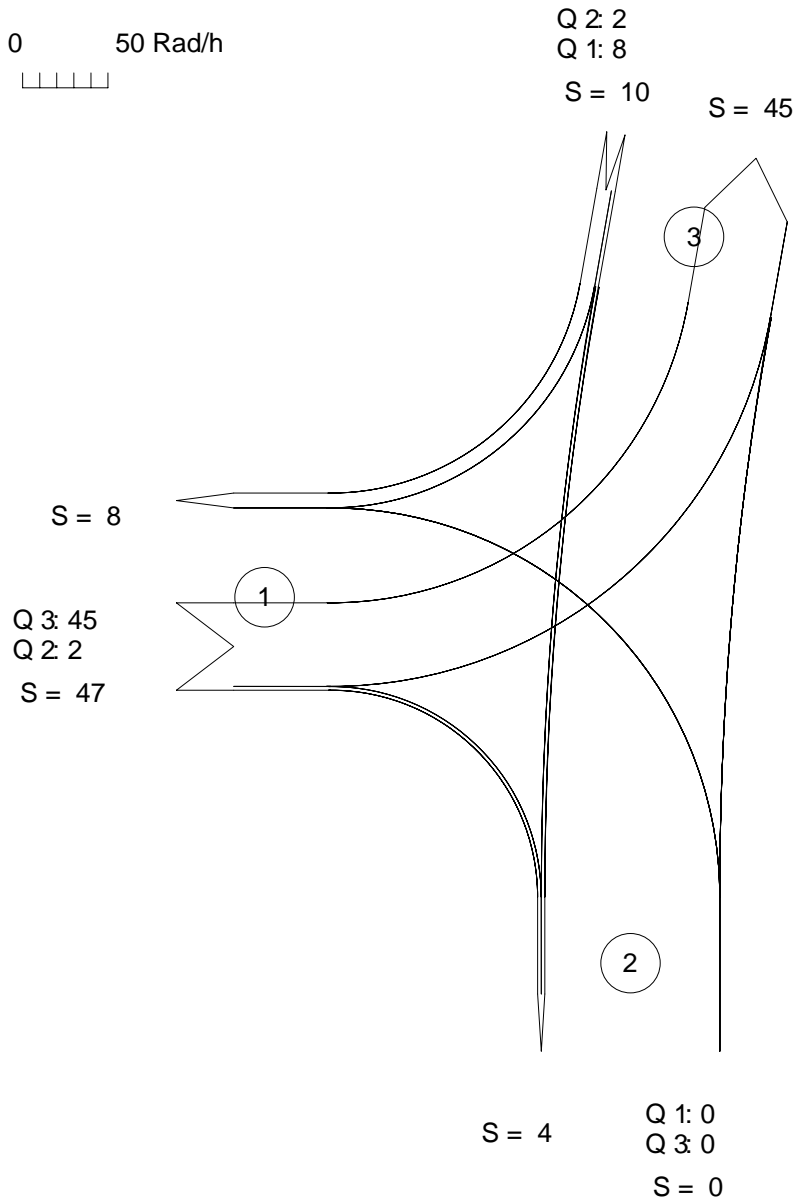

Summe = 57

Zufahrt 1: Meindorfer Straße - L16 / West
 Zufahrt 2: Am Bahnhof
 Zufahrt 3: Meindorfer Straße - L16 / Ost

Σ der Ströme nachmittags 16:00 - 17:00 Uhr (Spitzenstunde)

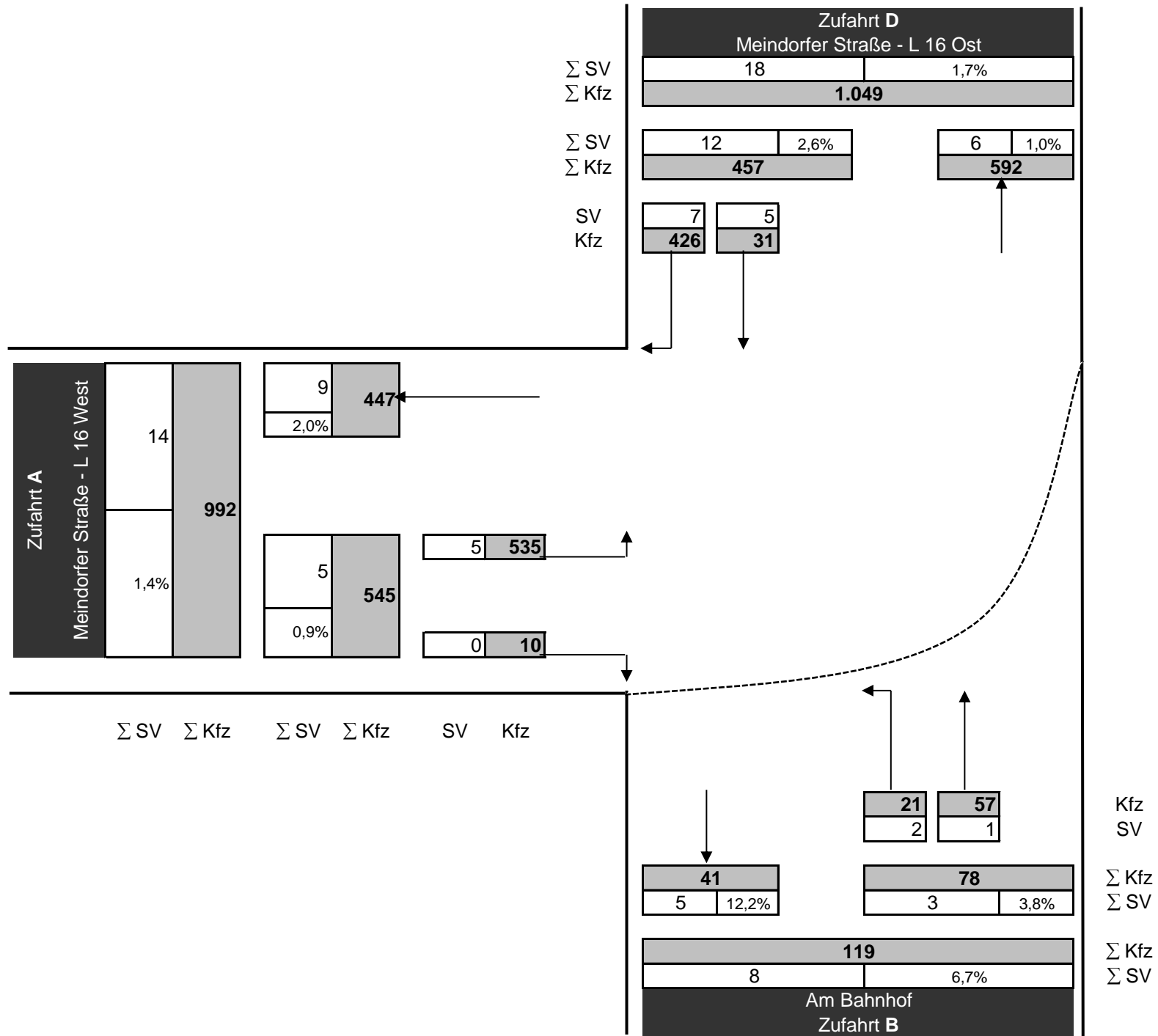

Verkehrsfluss - Diagramm als Kreuzung

Datei : SANKTAUGUSTIN_MENDEN2015_AMBAHNHOF_NM.kob
Projekt : Sankt-Augustin - GE Menden Süd 2015
Knoten : Meindorfer Straße / Am Bahnhof
Stunde : 16-17 Uhr

PKW-Einheiten

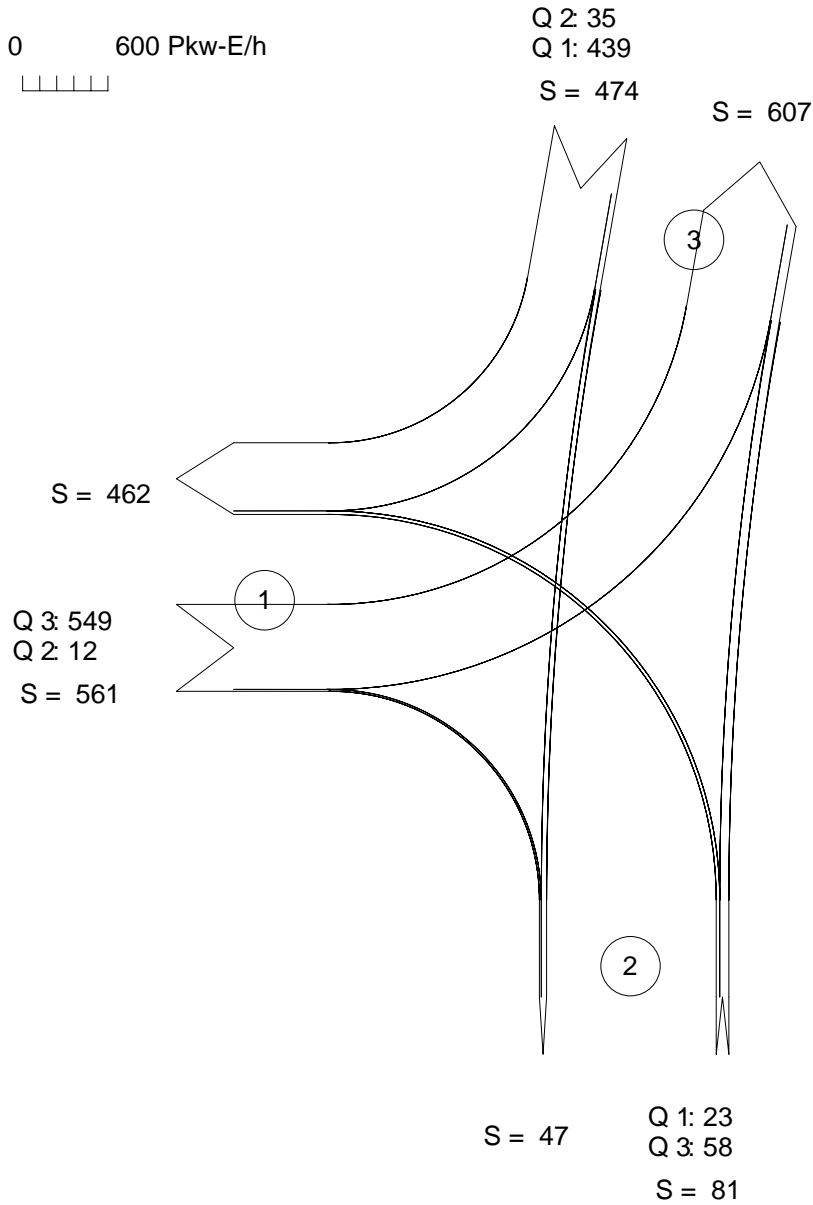

Summe = 1116

Zufahrt 1: Meindorfer Straße - L16 / West
Zufahrt 2: Am Bahnhof
Zufahrt 3: Meindorfer Straße - L16 / Ost

Verkehrsfluss - Diagramm als Kreuzung

Datei : SANKTAUGUSTIN_MENDEN2015_AMBAHNHOF_NM.kob
 Projekt : Sankt-Augustin - GE Menden Süd 2015
 Knoten : Meindorfer Straße / Am Bahnhof
 Stunde : 16-17 Uhr

Kraftfahrzeuge

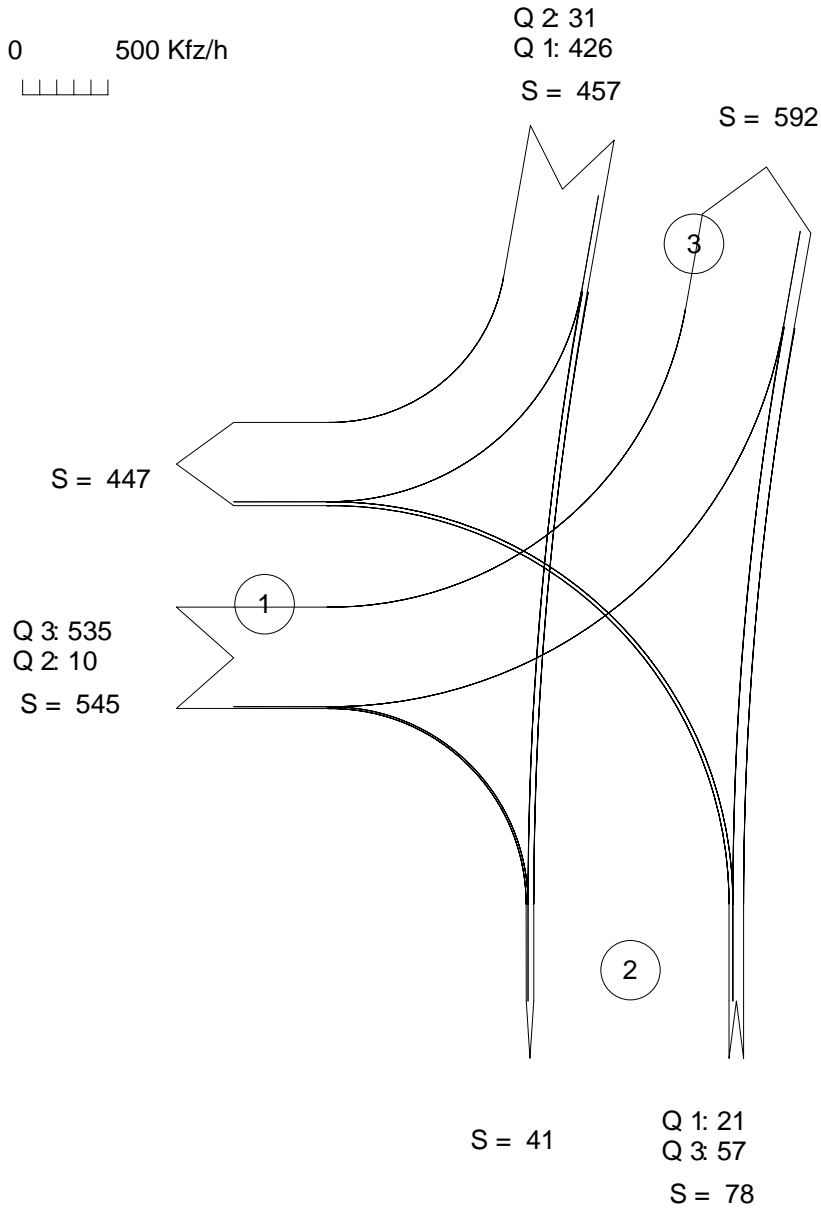

Summe = 1080

Zufahrt 1: Meindorfer Straße - L16 / West
 Zufahrt 2: Am Bahnhof
 Zufahrt 3: Meindorfer Straße - L16 / Ost

Verkehrsfluss - Diagramm als Kreuzung

Datei : SANKTAUGUSTIN_MENDEN2015_AMBAHNHOF_NM.kob
 Projekt : Sankt-Augustin - GE Menden Süd 2015
 Knoten : Meindorfer Straße / Am Bahnhof
 Stunde : 16-17 Uhr

Fahrrad

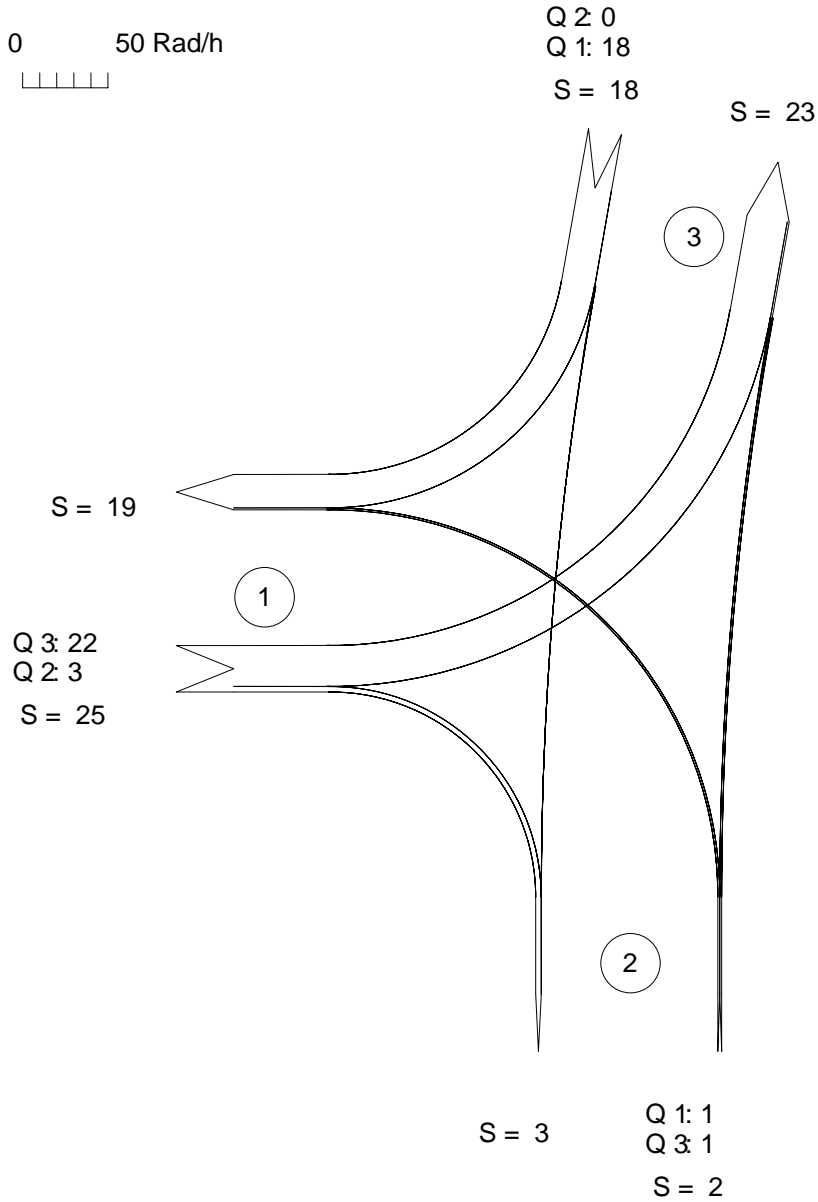

Summe = 45

Zufahrt 1: Meindorfer Straße - L16 / West
 Zufahrt 2: Am Bahnhof
 Zufahrt 3: Meindorfer Straße - L16 / Ost

Übersicht über die Knotenbelastungen

Summe der Zufahrten											
von - bis	Rad	Pkw	Lw	Lkw	Lz	Bus	Σ Kfz	Σ GV	GV[%]	Σ SV	SV[%]
07:00 - 08:00	57	809	58	13	2	14	896	73	8,1	29	3,2
08:00 - 09:00	23	639	45	16	1	9	710	62	8,7	26	3,7
15:00 - 16:00	39	710	31	14	2	10	767	47	6,1	26	3,4
16:00 - 17:00	45	1017	43	8	2	10	1.080	53	4,9	20	1,9
17:00 - 18:00	33	906	25	5	3	8	947	33	3,5	16	1,7
18:00 - 19:00	57	751	20	5	1	8	785	26	3,3	14	1,8
Σ 6 Stunden	254	4.832	222	61	11	59	5.185	294	5,7	131	2,5

Σ 7-9 Uhr	80	1.448	103	29	3	23	1.606	135	8,4	55	3,4
HF gesamt	6,3	6,3	6,3	6,1	6,1	6,1					
Tagesverkehr	500	9.050	644	176	18	139	10.027	838	8,4	333	3,3

Σ 15-19 Uhr	174	3.384	119	32	8	36	3.579	159	4,4	76	2,1
HF gesamt	3,1	3,1	3,1	5,3	5,3	5,3					
Tagesverkehr	534	10.389	365	168	42	189	11.154	576	5,2	400	3,6

Σ 6 Stunden	80	1.448	103	29	3	23	1.606	135	8,4	55	3,4
HF gesamt	2,1	2,1	2,1	2,8	2,8	2,8					
Tagesverkehr	165	2.983	212	82	8	65	3.350	302	9,0	155	4,6

Σ 16-19 Uhr	135	2.674	88	18	6	26	2.812	112	4,0	50	1,8
HF gesamt	4,2	4,2	6,0	8,6	8,6	6,0					
Tagesverkehr	567	11.231	528	155	52	156	12.121	734	6,1	362	3,0

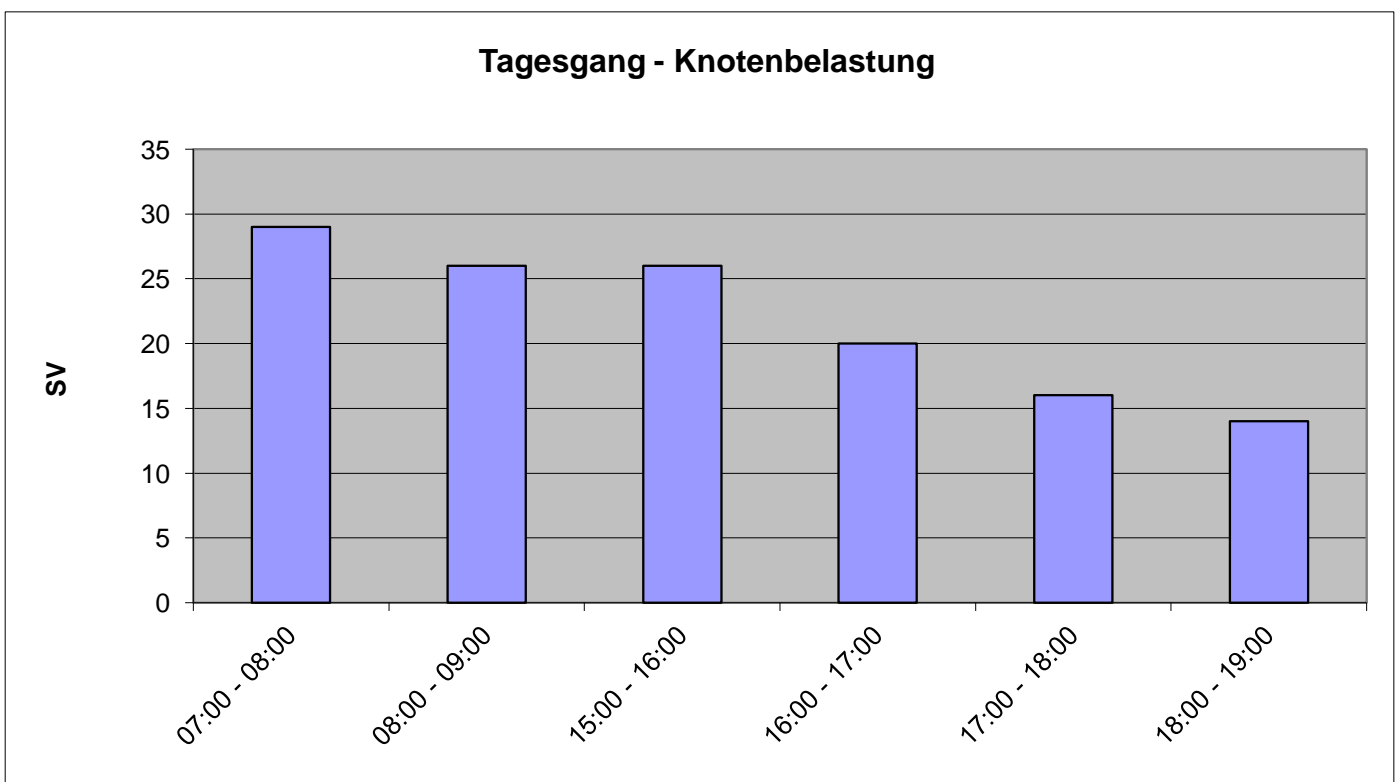
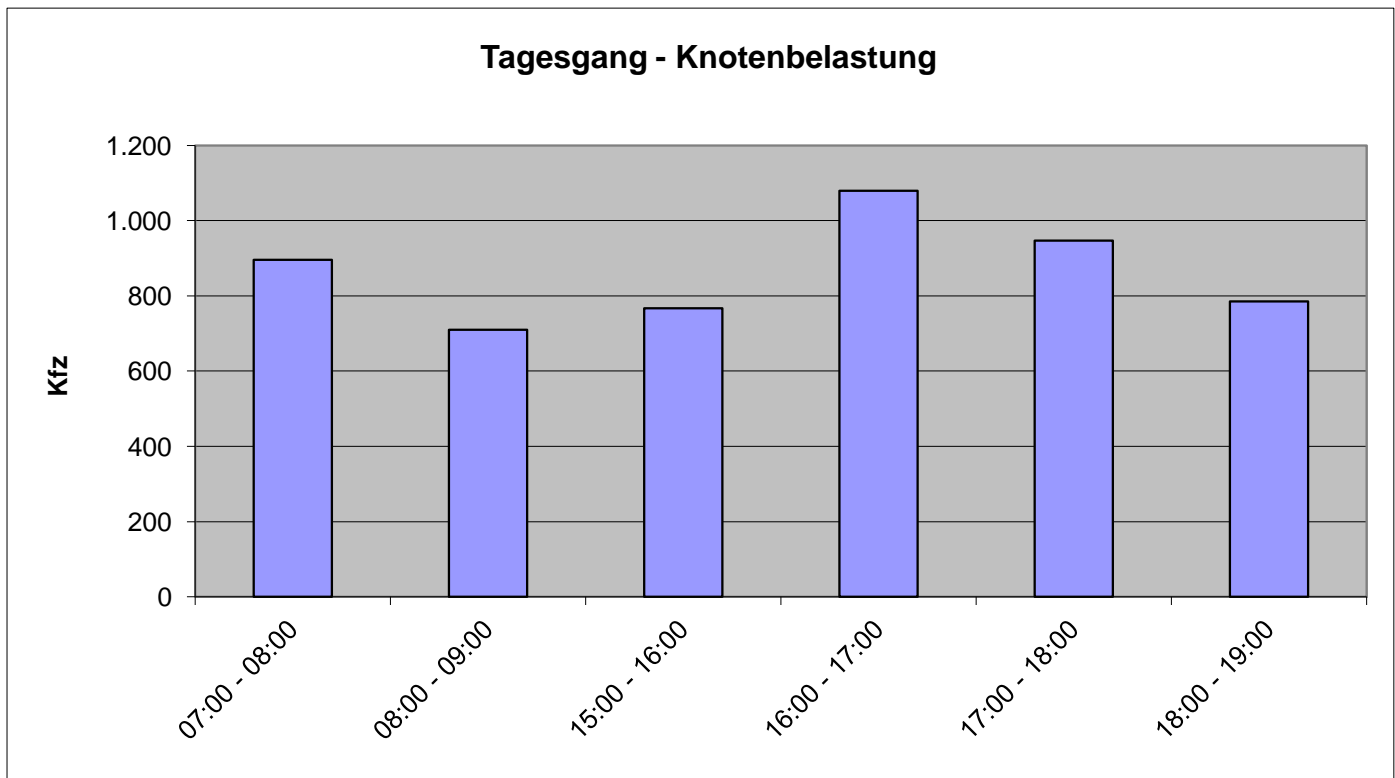

Sankt Augustin

Verkehrszählung am 24.06.2015

Standort-Nr. 1

Übersicht über die Querschnittsbelastungen

Querschnitt A - Meindorfer Straße - L 16 West											
von - bis	Rad	Pkw	Lw	Lkw	Lz	Bus	Σ Kfz	Σ GV	GV [%]	Σ SV	SV [%]
07:00 - 08:00	55	776	43	5	0	14	838	48	5,7	19	2,3
08:00 - 09:00	23	603	36	6	0	9	654	42	6,4	15	2,3
15:00 - 16:00	38	671	23	3	0	10	707	26	3,7	13	1,8
16:00 - 17:00	44	951	27	4	0	10	992	31	3,1	14	1,4
17:00 - 18:00	33	849	20	4	0	8	881	24	2,7	12	1,4
18:00 - 19:00	57	721	17	1	0	8	747	18	2,4	9	1,2
Σ 6 Stunden	250	4.571	166	23	0	59	4.819	189	3,9	82	1,7

Σ 7-9 Uhr	78	1.379	79	11	0	23	1.492	90	6,0	34	2,3
HF gesamt	6,3	6,3	6,3	6,1	6,1	6,1					
Tagesverkehr	488	8.619	494	67	0	139	9.319	560	6,0	206	2,2

Σ 15-19 Uhr	172	3.192	87	12	0	36	3.327	99	3,0	48	1,4
HF gesamt	3,1	3,1	3,1	5,3	5,3	5,3					
Tagesverkehr	528	9.799	267	63	0	189	10.319	330	3,2	252	2,4

Σ 6 Stunden	250	4.571	166	23	0	59	4.819	189	3,9	82	1,7
HF gesamt	2,1	2,1	2,1	2,8	2,8	2,8					
Tagesverkehr	515	9.416	342	65	0	166	9.989	407	4,1	231	2,3

Σ 16-19 Uhr	134	2.521	64	9	0	26	2.620	73	2,8	35	1,3
HF gesamt	4,2	4,2	6,0	8,6	8,6	6,0					
Tagesverkehr	563	10.588	384	77	0	156	11.206	461	4,1	233	2,1

Querschnitt B - Am Bahnhof											
von - bis	Rad	Pkw	Lw	Lkw	Lz	Bus	Σ Kfz	Σ GV	GV [%]	Σ SV	SV [%]
07:00 - 08:00	4	47	21	11	2	0	81	34	42,0	13	16,0
08:00 - 09:00	0	52	11	12	1	0	76	24	31,6	13	17,1
15:00 - 16:00	6	60	13	13	2	0	88	28	31,8	15	17,0
16:00 - 17:00	5	93	18	6	2	0	119	26	21,8	8	6,7
17:00 - 18:00	4	79	5	2	3	0	89	10	11,2	5	5,6
18:00 - 19:00	7	39	4	4	1	0	48	9	18,8	5	10,4
Σ 6 Stunden	26	370	72	48	11	0	501	131	26,1	59	11,8

Σ 7-9 Uhr	4	99	32	23	3	0	157	58	36,9	26	16,6
HF gesamt	6,3	6,3	6,3	6,1	6,1	6,1					
Tagesverkehr	25	619	200	139	18	0	976	358	36,6	158	16,1

Σ 15-19 Uhr	22	271	40	25	8	0	344	73	21,2	33	9,6
HF gesamt	3,1	3,1	3,1	5,3	5,3	5,3					
Tagesverkehr	68	832	123	132	42	0	1.128	296	26,3	174	15,4

Σ 6 Stunden	26	370	72	48	11	0	501	131	26,1	59	11,8
HF gesamt	2,1	2,1	2,1	2,8	2,8	2,8					
Tagesverkehr	54	762	148	135	31	0	1.077	315	29,2	166	15,4

Σ 16-19 Uhr	16	211	27	12	6	0	256	45	17,6	18	7,0
HF gesamt	4,2	4,2	6,0	8,6	8,6	6,0					
Tagesverkehr	67	886	162	103	52	0	1.203	317	26,3	155	12,9

Querschnitt D - Meindorfer Straße - L 16 Ost											
von - bis	Rad	Pkw/Krad	Lw	Lkw	Lz	Bus	Σ Kfz	Σ GV	GV [%]	Σ SV	SV [%]
07:00 - 08:00	55	795	52	10	2	14	873	64	7,3	26	3,0
08:00 - 09:00	23	623	43	14	1	9	690	58	8,4	24	3,5
15:00 - 16:00	34	689	26	12	2	10	739	40	5,4	24	3,2
16:00 - 17:00	41	990	41	6	2	10	1.049	49	4,7	18	1,7
17:00 - 18:00	29	884	25	4	3	8	924	32	3,5	15	1,6
18:00 - 19:00	50	742	19	5	1	8	775	25	3,2	14	1,8
Σ 8 Stunden	232	4.723	206	51	11	59	5.050	268	5,3	121	2,4

Σ 7-9 Uhr	78	1.418	95	24	3	23	1.563	122	7,8	50	3,2
HF gesamt	6,3	6,3	6,3	6,1	6,1	6,1					
Tagesverkehr	488	8.863	594	145	18	139	9.759	757	7,8	303	3,1

Σ 15-19 Uhr	154	3.305	111	27	8	36	3.487	146	4,2	71	2,0
HF gesamt	3,1	3,1	3,1	5,3	5,3	5,3					
Tagesverkehr	473	10.146	341	142	42	189	10.861	525	4,8	373	3,4

Σ 6 Stunden	232	4.723	206	51	11	59	5.050	268	5,3	121	2,4
HF gesamt	2,1	2,1	2,1	2,8	2,8	2,8					
Tagesverkehr	478	9.729	424	144	31	166	10.495	599	5,7	341	3,3

Σ 16-19 Uhr	120	2.616	85	15	6	26	2.748	106	3,9	47	1,7
HF gesamt	4,2	4,2	6,0	8,6	8,6	6,0					
Tagesverkehr	504	10.987	510	129	52	156	11.834	691	5,8	337	2,8

Übersicht über die Tagesgänge der Kfz-Querschnittsbelastungen

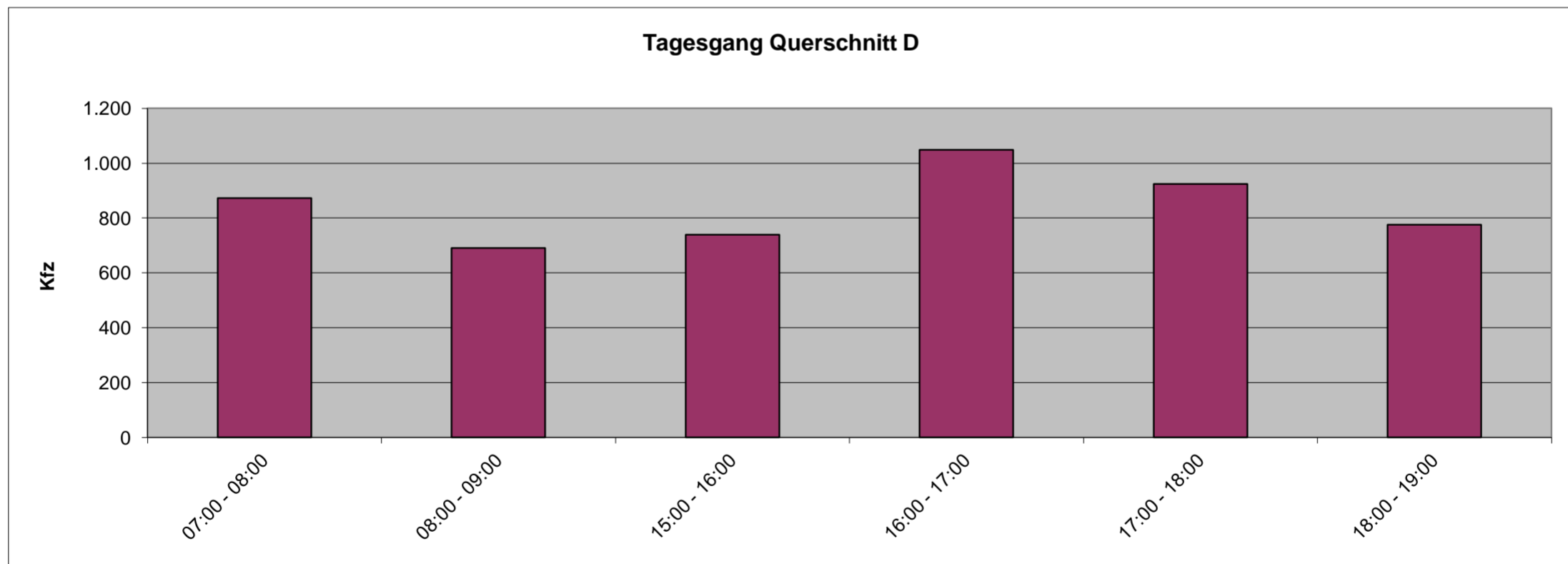
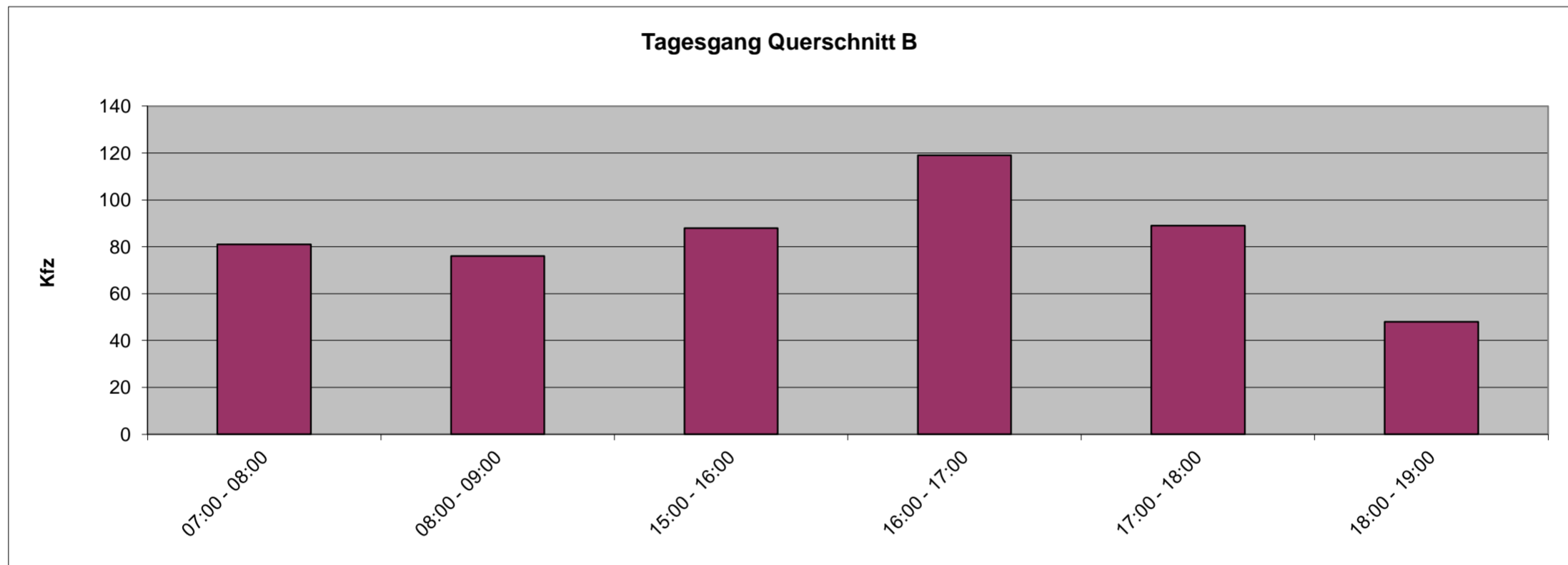
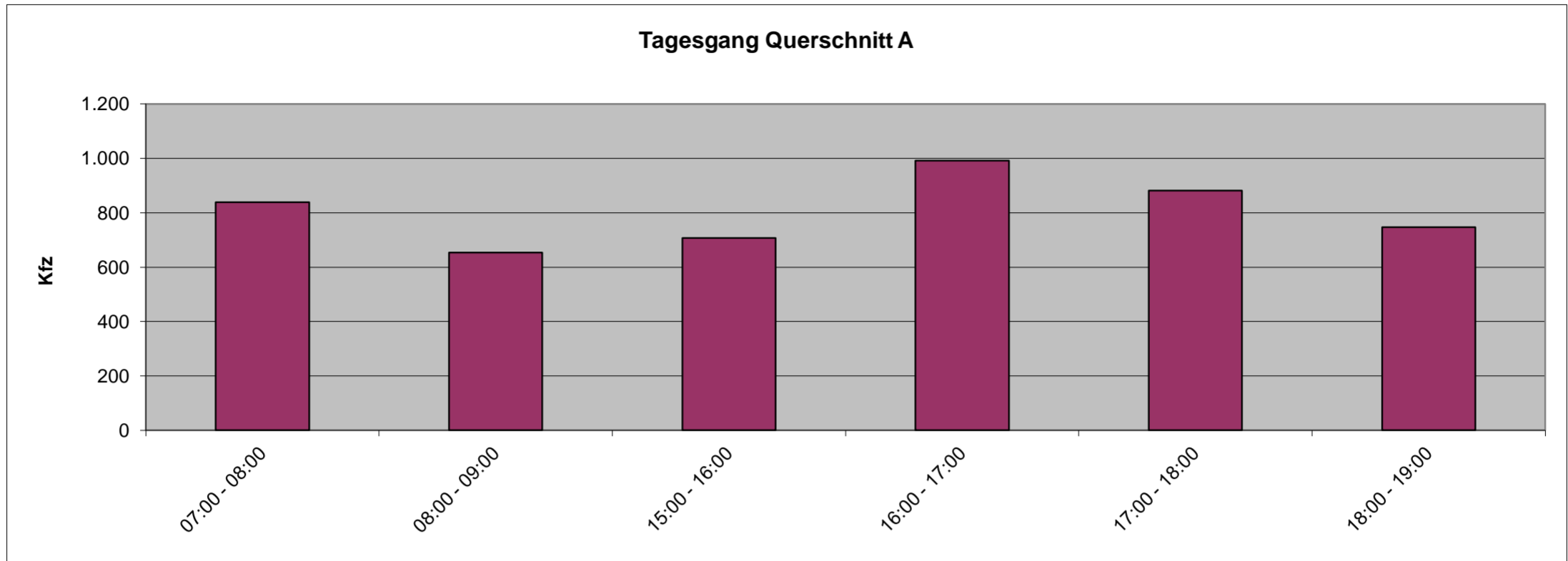

Übersicht über die Tagesgänge der SV-Querschnittsbelastungen

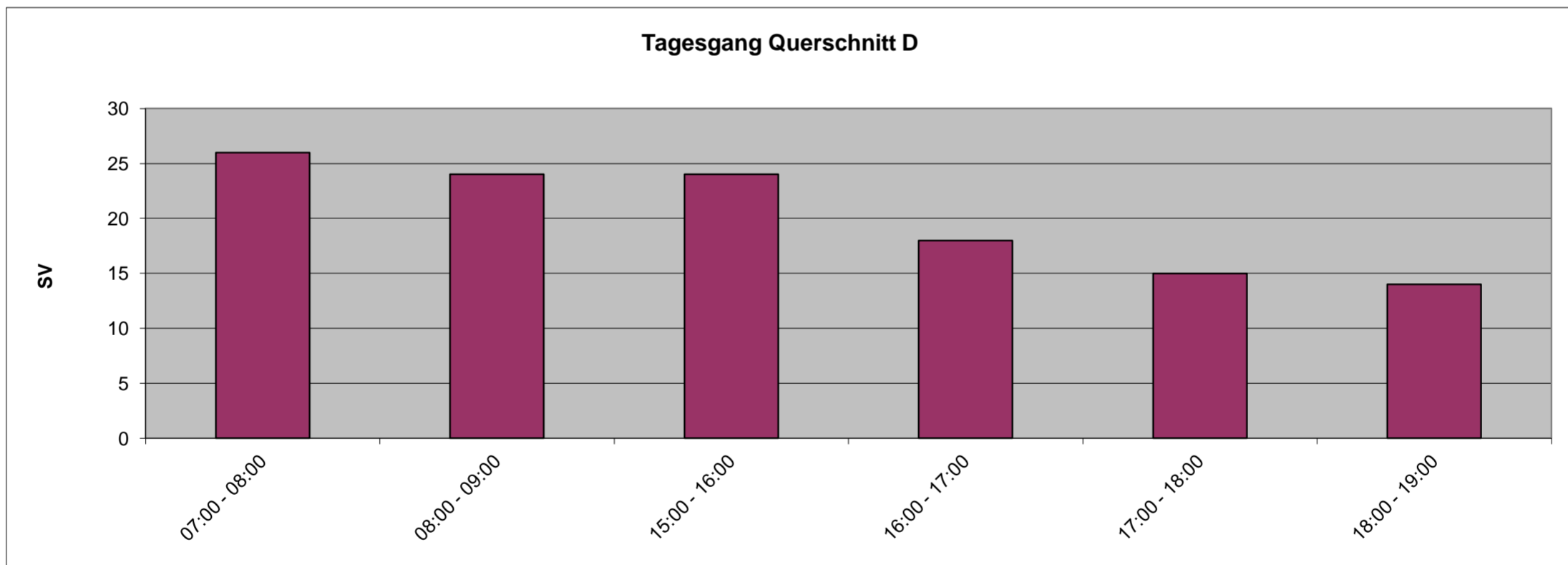
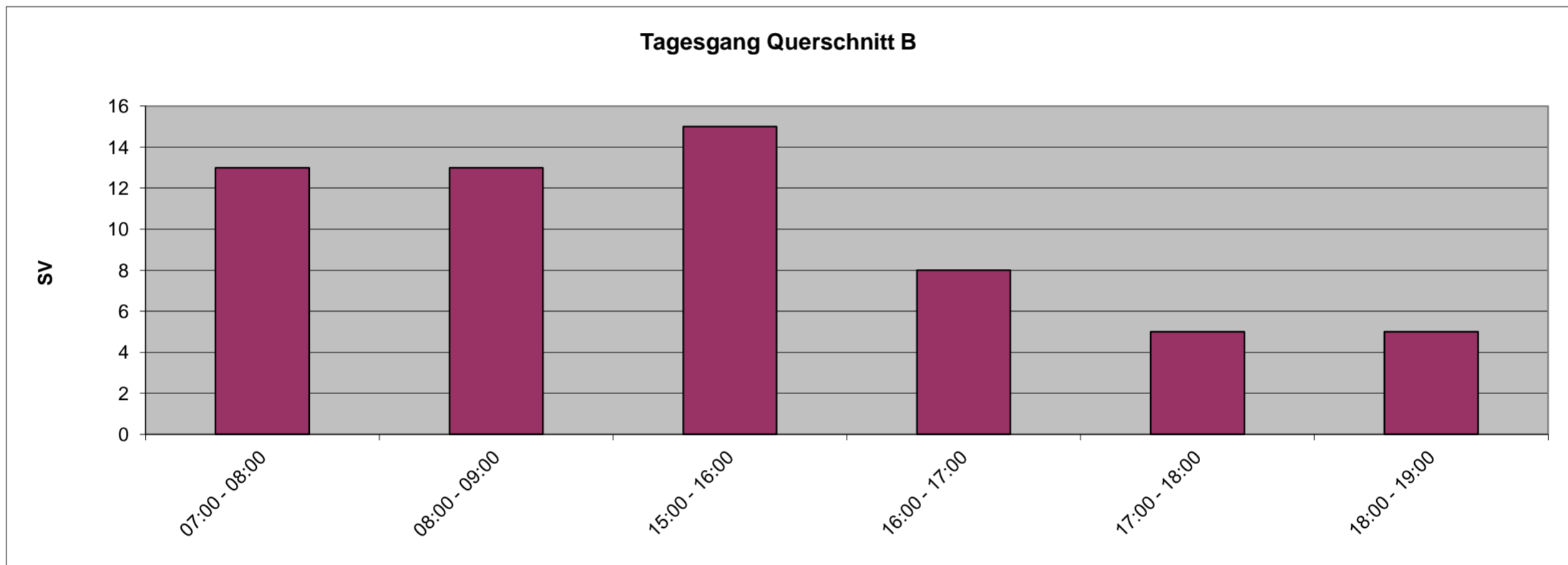
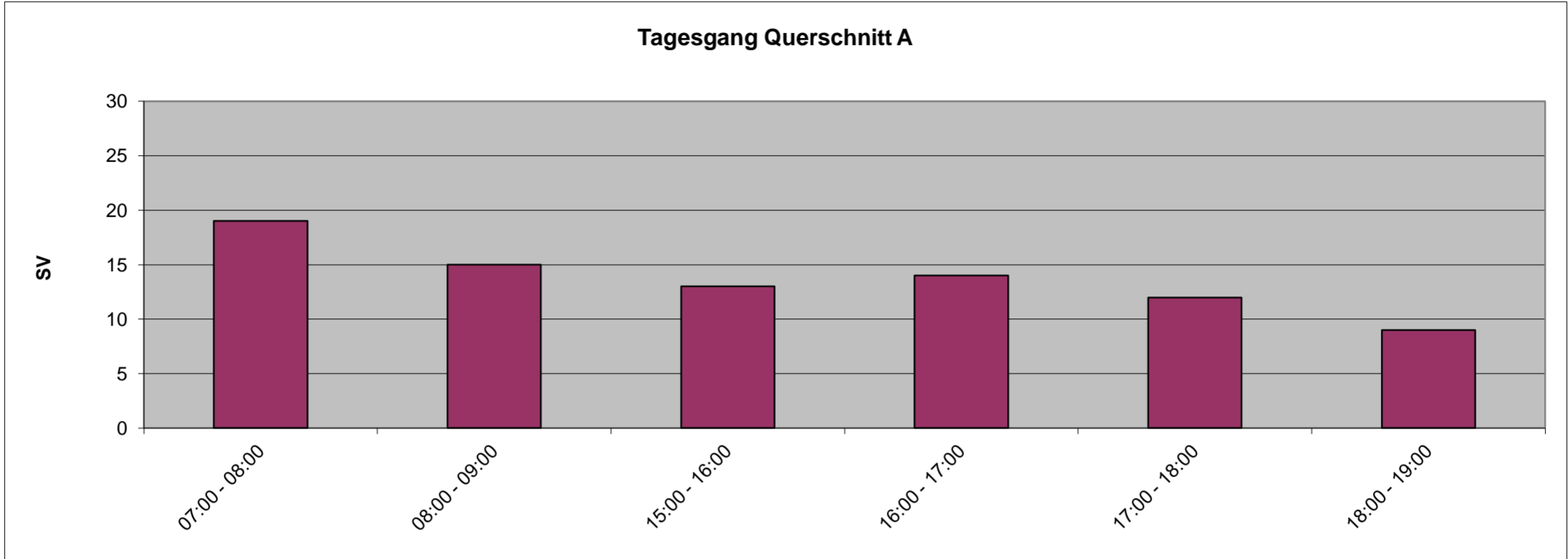

Sankt Augustin

Verkehrszählung am 24.06.2015

Standort-Nr. 1

Übersicht über die Zufahrtsbelastungen

Zufahrt A - Meindorfer Straße - L 16 West											
von - bis	Rad	Pkw	Lw	Lkw	Lz	Bus	Σ Kfz	Σ GV	GV [%]	Σ SV	SV [%]
07:00 - 08:00	47	344	16	2	0	5	367	18	4,9	7	1,9
08:00 - 09:00	11	256	14	1	0	5	276	15	5,4	6	2,2
15:00 - 16:00	11	369	8	2	0	5	384	10	2,6	7	1,8
16:00 - 17:00	25	527	13	0	0	5	545	13	2,4	5	0,9
17:00 - 18:00	10	468	10	3	0	4	485	13	2,7	7	1,4
18:00 - 19:00	32	395	7	1	0	4	407	8	2,0	5	1,2
Σ 6 Stunden	136	2.359	68	9	0	28	2.464	77	3,1	37	1,5

Σ 7-9 Uhr	58	600	30	3	0	10	643	33	5,1	13	2,0
HF gesamt	6,3	6,3	6,3	6,1	6,1	6,1					
Tagesverkehr	363	3.750	188	18	0	61	4.016	206	5,1	79	2,0

Σ 15-19 Uhr	78	1.759	38	6	0	18	1.821	44	2,4	24	1,3
HF gesamt	3,1	3,1	3,1	5,3	5,3	5,3					
Tagesverkehr	239	5.400	117	32	0	95	5.643	148	2,6	126	2,2

Σ 6 Stunden	136	2.359	68	9	0	28	2.464	77	3,1	37	1,5
HF gesamt	2,1	2,1	2,1	2,8	2,8	2,8					
Tagesverkehr	280	4.860	140	25	0	79	5.104	165	3,2	104	2,0

Σ 16-19 Uhr	67	1.390	30	4	0	13	1.437	34	2,4	17	1,2
HF gesamt	4,2	4,2	6,0	8,6	8,6	6,0					
Tagesverkehr	281	5.838	180	34	0	78	6.130	214	3,5	112	1,8

Zufahrt B - Am Bahnhof											
von - bis	Rad	Pkw	Lw	Lkw	Lz	Bus	Σ Kfz	Σ GV	GV [%]	Σ SV	SV [%]
07:00 - 08:00	0	11	14	8	2	0	35	24	68,6	10	28,6
08:00 - 09:00	0	23	6	7	0	0	36	13	36,1	7	19,4
15:00 - 16:00	1	37	5	6	0	0	48	11	22,9	6	12,5
16:00 - 17:00	2	68	7	3	0	0	78	10	12,8	3	3,8
17:00 - 18:00	4	58	3	0	1	0	62	4	6,5	1	1,6
18:00 - 19:00	5	21	3	3	0	0	27	6	22,2	3	11,1
Σ 6 Stunden	12	218	38	27	3	0	286	68	23,8	30	10,5

Σ 7-9 Uhr	0	34	20	15	2	0	71	37	52,1	17	23,9
HF gesamt	6,3	6,3	6,3	6,1	6,1	6,1					
Tagesverkehr	0	213	125	91	12	0	441	228	51,8	103	23,4

Σ 15-19 Uhr	12	184	18	12	1	0	215	31	14,4	13	6,0
HF gesamt	3,1	3,1	3,1	5,3	5,3	5,3					
Tagesverkehr	37	565	55	63	5	0	689	124	18,0	68	9,9

Σ 6 Stunden	12	218	38	27	3	0	286	68	23,8	30	10,5
HF gesamt	2,1	2,1	2,1	2,8	2,8	2,8					
Tagesverkehr	25	449	78	76	8	0	612	163	26,6	85	13,8

Σ 16-19 Uhr	11	147	13	6	1	0	167	20	12,0	7	4,2
HF gesamt	4,2	4,2	6,0	8,6	8,6	6,0					
Tagesverkehr	46	617	78	52	9	0	756	138	18,3	60	8,0

Zufahrt D - Meindorfer Straße - L 16 Ost											
von - bis	Rad	Pkw/Krad	Lw	Lkw	Lz	Bus	Σ Kfz	Σ GV	GV [%]	Σ SV	SV [%]
07:00 - 08:00	10	454	28	3	0	9	494	31	6,3	12	2,4
08:00 - 09:00	12	360	25	8	1	4	398	34	8,5	13	3,3
15:00 - 16:00	27	304	18	6	2	5	335	26	7,8	13	3,9
16:00 - 17:00	18	422	23	5	2	5	457	30	6,6	12	2,6
17:00 - 18:00	19	380	12	2	2	4	400	16	4,0	8	2,0
18:00 - 19:00	20	335	10	1	1	4	351	12	3,4	6	1,7
Σ 6 Stunden	106	2.255	116	25	8	31	2.435	149	6,1	64	2,6

Σ 7-9 Uhr	22	814	53	11	1	13	892	65	7,3	25	2,8
HF gesamt	6,3	6,3	6,3	6,1	6,1	6,1					
Tagesverkehr	138	5.088	331	67	6	79	5.570	404	7,3	152	2,7

Σ 15-19 Uhr	84	1.441	63	14	7	18	1.543	84	5,4	39	2,5
HF gesamt	3,1	3,1	3,1	5,3	5,3	5,3					
Tagesverkehr	258	4.424	193	74	37	95	4.822	304	6,3	205	4,3

Σ 6 Stunden	106	2.255	116	25	8	31	2.435	149	6,1	64	2,6
HF gesamt	2,1	2,1	2,1	2,8	2,8	2,8					
Tagesverkehr	218	4.645	239	71	23	87	5.065	332	6,6	180	3,6

Σ 16-19 Uhr	57	1.137	45	8	5	13	1.208	58	4,8	26	2,2
HF gesamt	4,2	4,2	6,0	8,6	8,6	6,0					
Tagesverkehr	239	4.775	270	69	43	78	5.235	382	7,3	190	3,6

Übersicht über die Tagesgänge der Kfz-Zufahrtsbelastungen

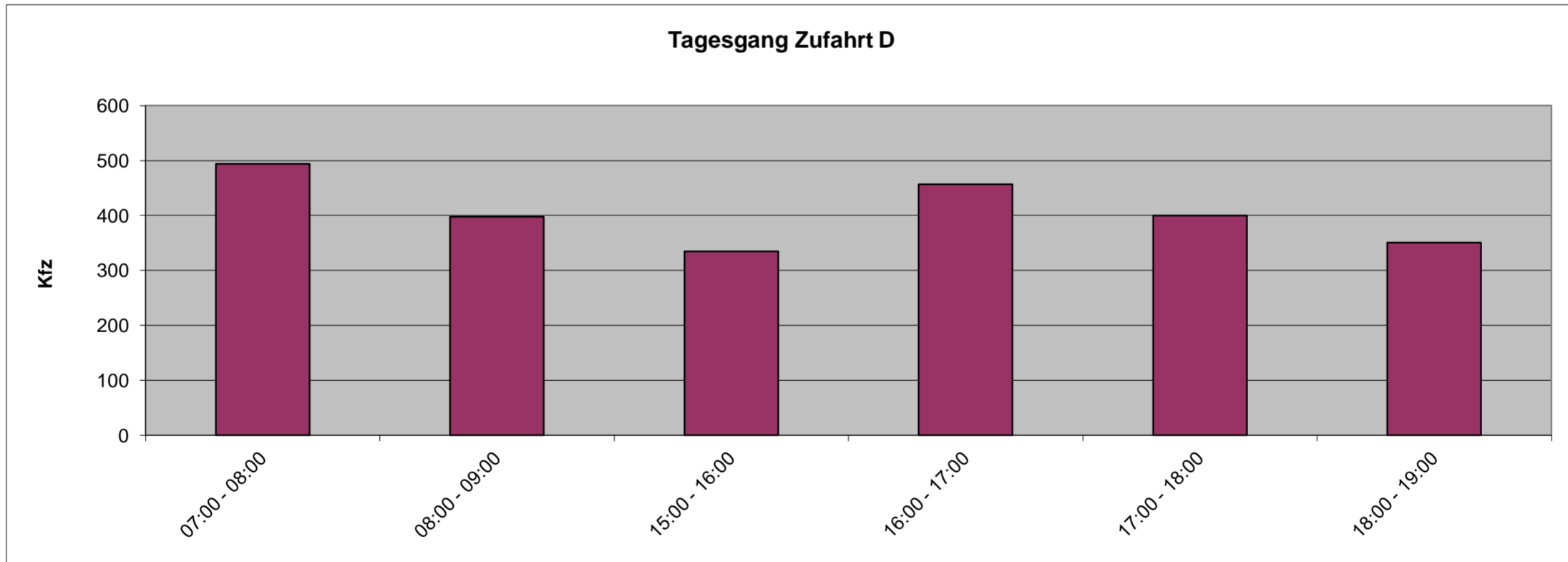
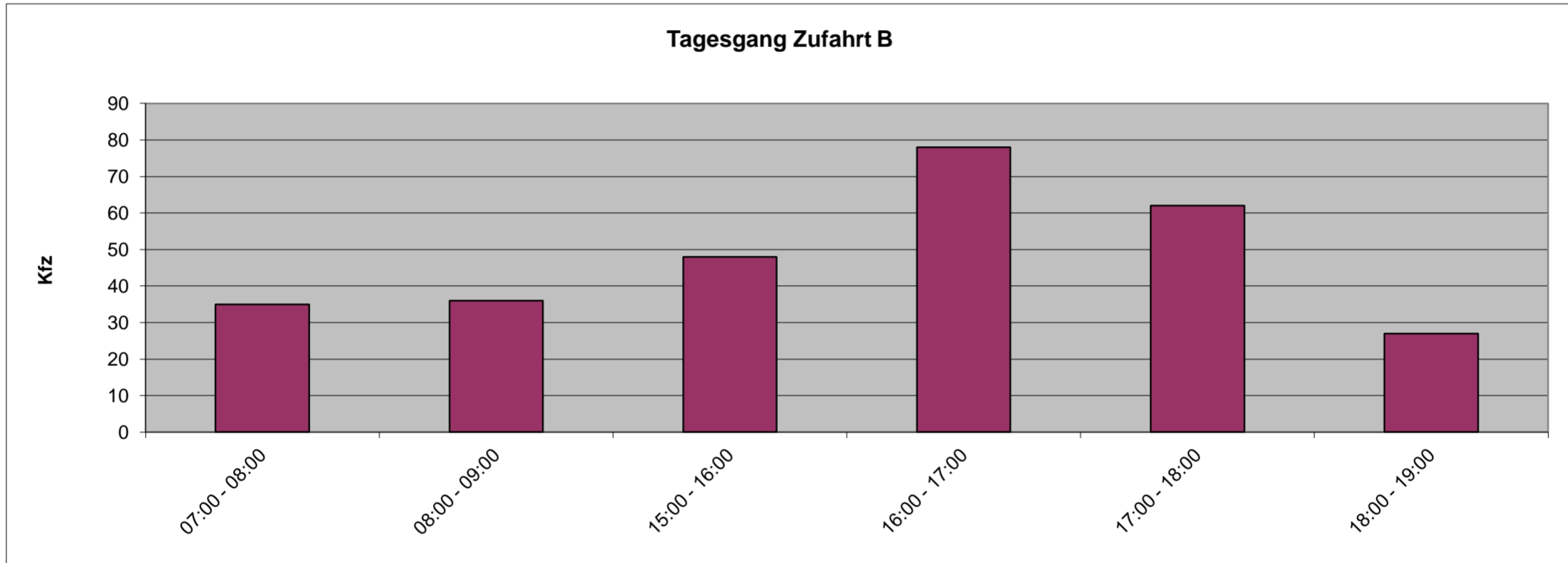
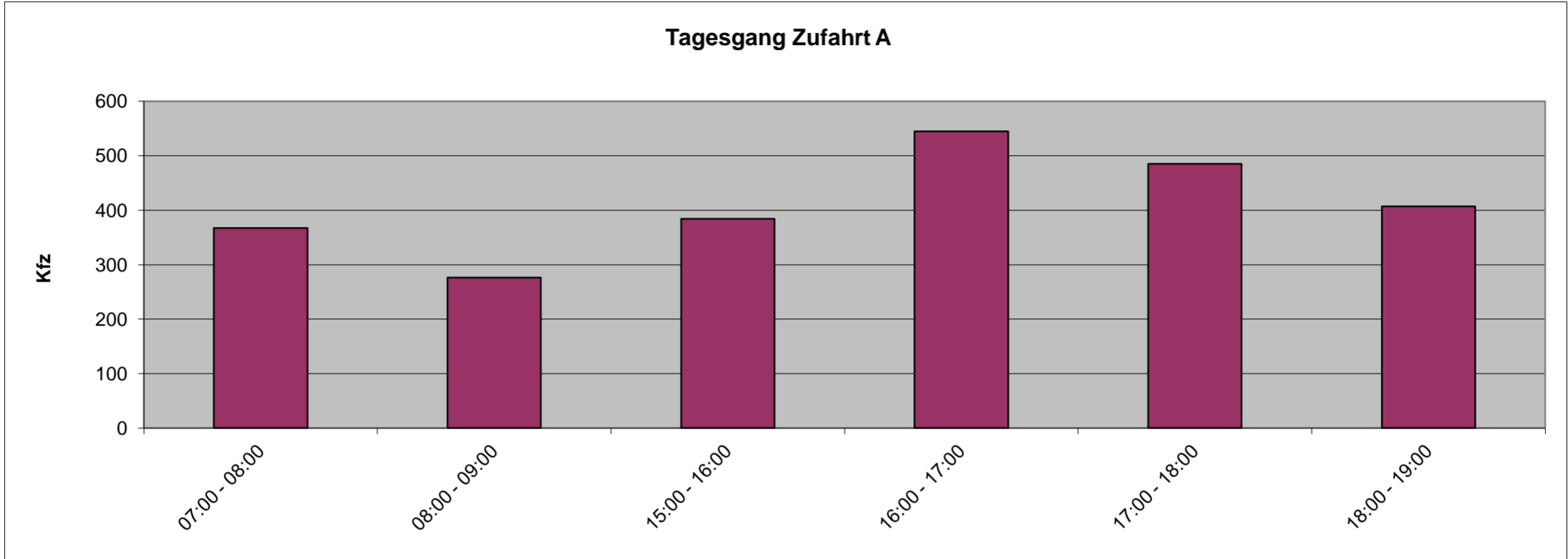

Übersicht über die Tagesgänge der SV-Zufahrtsbelastungen

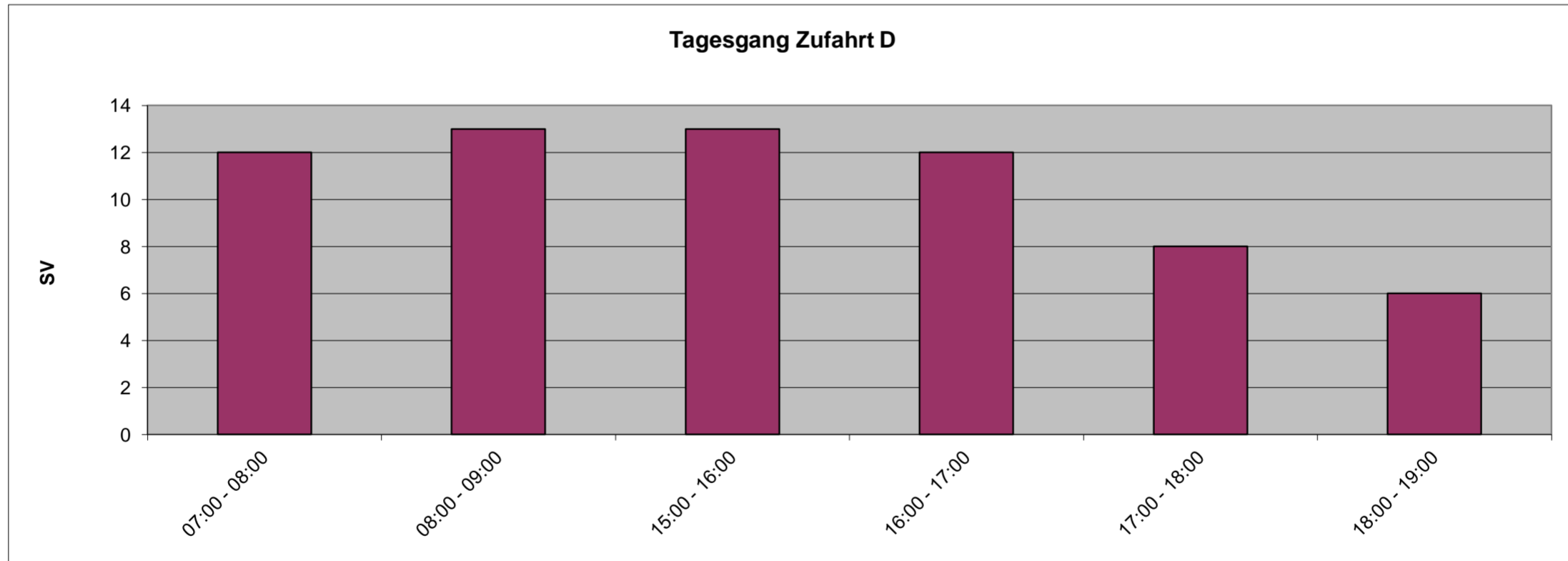
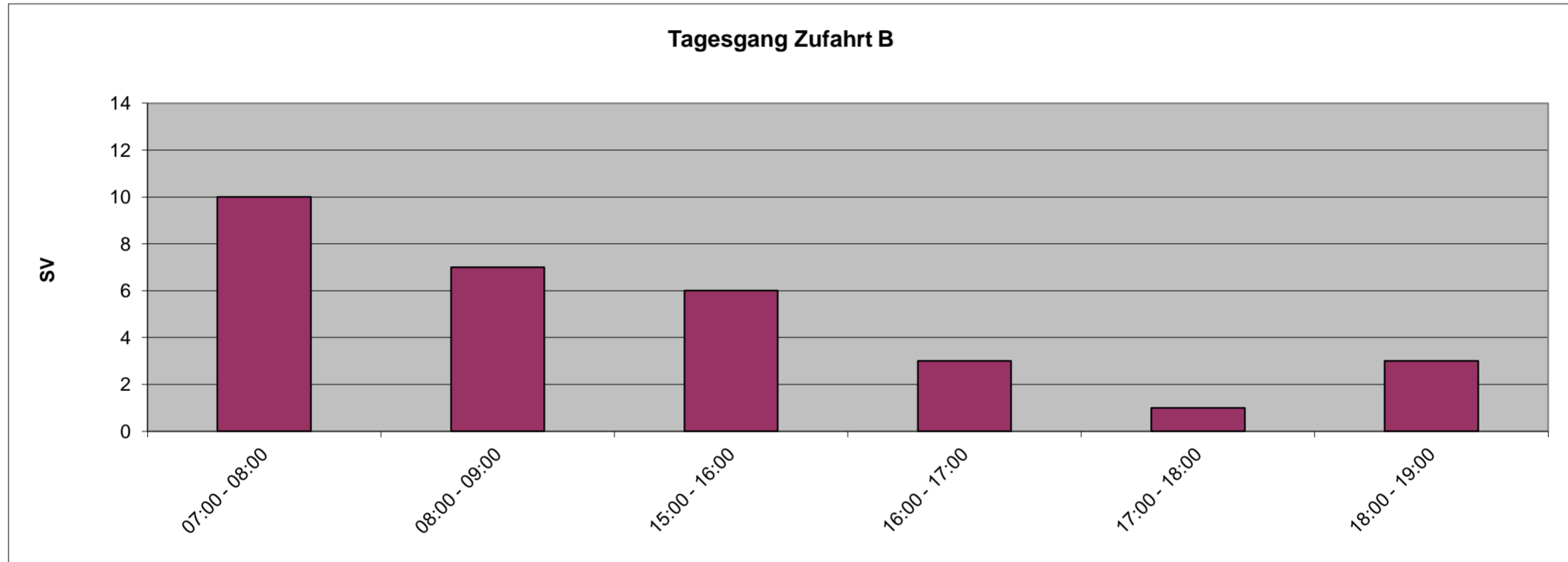
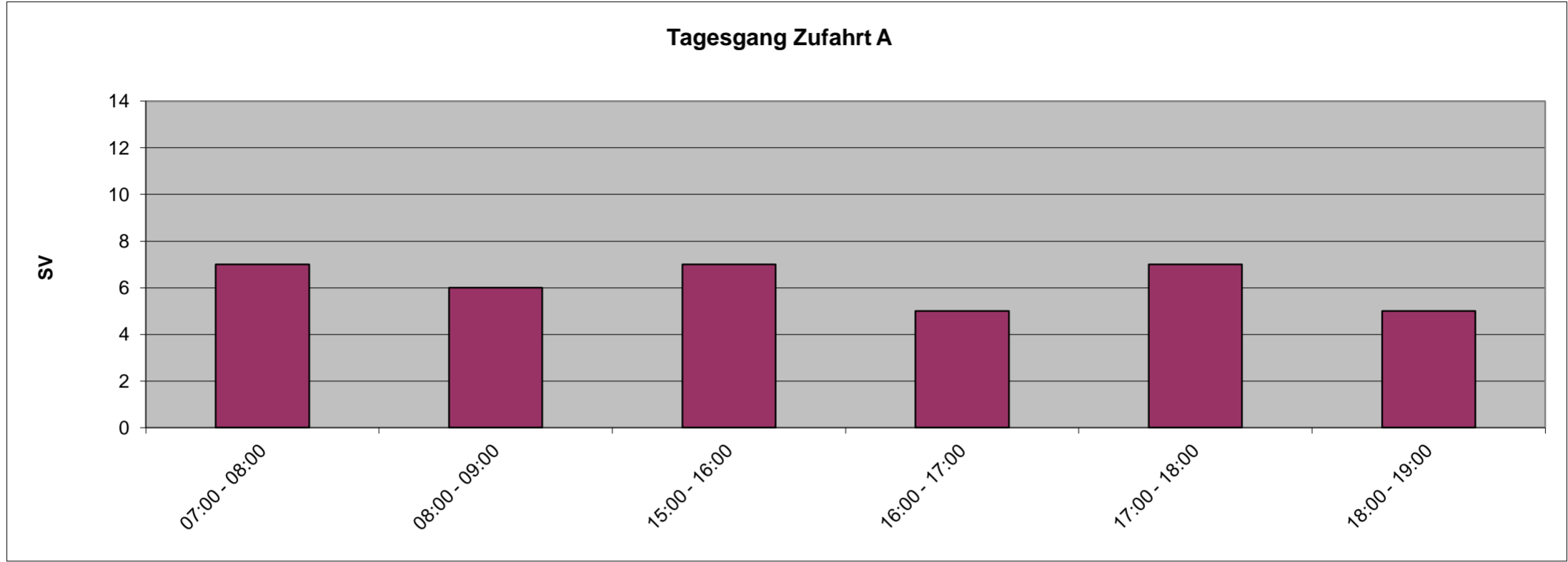

Zufahrt A - Blatt 1
Meindorfer Straße - L 16 West

Zufahrt A - Blatt 2
Meindorfer Straße - L 16 West

Summe in der Zufahrt

von A nach B
Meindorfer Straße - L 16 West --> Am Bahnhof

von A nach D
Meindorfer Straße - L 16 West --> Meindorfer Straße - L 16 Ost

Zeit von - bis	von A nach B										von A nach D										Summe in der Zufahrt									
	Rad	Pkw/Krad	Lw	Lkw	Lz	Bus	Σ Kfz	Σ GV	Σ SV	Rad	Pkw/Krad	Lw	Lkw	Lz	Bus	Σ Kfz	Σ GV	Σ SV	Rad	Pkw/Krad	Lw	Lkw	Lz	Bus	Σ Kfz	Σ GV	GV [%]	Σ SV	SV [%]	
7:00 - 7:15	1	1	0	0	0	0	1	0	0	3	55	3	0	0	3	61	3	3	4	56	3	0	0	3	62	3	4,8	3	4,8	
7:15 - 7:30	0	4	1	0	0	0	5	1	0	13	71	3	1	0	1	76	4	2	13	75	4	1	0	1	81	5	6,2	2	2,5	
7:30 - 7:45	1	3	0	0	0	0	3	0	0	21	94	3	0	0	0	97	3	0	22	97	3	0	0	0	100	3	3,0	0	0,0	
7:45 - 8:00	0	2	0	1	0	0	3	1	1	8	114	6	0	0	1	121	6	1	8	116	6	1	0	1	124	7	5,6	2	1,6	
8:00 - 8:15	0	2	0	0	0	0	2	0	0	1	64	1	0	0	3	68	1	3	1	66	1	1	0	3	70	1	1,4	3	4,3	
8:15 - 8:30	0	2	1	0	0	0	3	1	0	4	63	4	0	0	1	68	4	1	4	65	5	0	0	1	71	5	7,0	1	1,4	
8:30 - 8:45	0	1	0	0	0	0	1	0	0	5	70	2	0	0	1	73	2	1	0	71	2	0	0	1	74	2	2,7	1	1,4	
8:45 - 9:00	0	2	1	1	0	0	4	2	1	1	52	5	0	0	0	57	5	0	5	54	6	1	0	0	61	7	11,5	1	1,6	
15:00 - 15:15	0	2	1	0	0	0	3	1	0	2	91	3	0	0	2	96	3	2	2	93	4	0	0	2	99	4	4,0	2	2,0	
15:15 - 15:30	1	1	0	0	0	0	1	0	0	1	69	1	0	0	1	71	1	1	2	70	1	0	0	1	72	1	1,4	1	1,4	
15:30 - 15:45	0	0	0	0	0	0	0	0	0	2	103	1	0	0	1	105	1	1	2	103	1	0	0	1	105	1	1,0	1	1,0	
15:45 - 16:00	3	2	1	2	0	0	5	3	2	2	101	1	0	0	1	103	1	1	5	103	2	2	0	1	108	4	3,7	3	2,8	
16:00 - 16:15	1	0	2	0	0	0	2	2	0	7	116	1	0	0	2	119	1	2	8	116	3	0	0	2	121	3	2,5	2	1,7	
16:15 - 16:30	0	6	0	0	0	0	6	0	0	4	136	2	0	0	1	139	2	1	4	142	2	0	0	1	145	2	1,4	1	0,7	
16:30 - 16:45	0	0	0	0	0	0	0	0	0	10	114	3	0	0	2	119	3	2	10	114	3	0	0	2	119	3	2,5	2	1,7	
16:45 - 17:00	2	2	0	0	0	0	2	0	0	1	153	5	0	0	0	158	5	0	3	155	5	0	0	0	160	5	3,1	0	0,0	
17:00 - 17:15	0	1	0	1	0	0	2	1	1	1	130	3	2	0	2	137	5	4	1	131	3	1	0	2	139	6	4,3	5	3,6	
17:15 - 17:30	0	3	0	0	0	0	3	0	0	4	125	2	0	0	1	128	2	1	4	128	2	0	0	1	131	2	1,5	1	0,8	
17:30 - 17:45	0	0	0	0	0	0	0	0	0	3	109	2	0	0	1	112	2	1	3	109	2	0	0	1	112	2	1,8	1	0,9	
17:45 - 18:00	0	0	0	0	0	0	0	0	0	2	100	3	0	0	0	103	3	0	2	100	3	0	0	0	103	3	2,9	0	0,0	
18:00 - 18:15	1	1	0	0	0	0	1	0	0	10	103	2	0	0	2	107	2	2	11	104	2	0	0	2	108	2	1,9	2	1,9	
18:15 - 18:30	0	1	0	0	0	0	1	0	0	13	82	1	0	0	1	84	1	1	13	83	1	0	0	1	85	1	1,2	1	1,2	
18:30 - 18:45	0	0	0	0	0	0	0	0	0	2	106	2	0	0	1	109	2	1	2	106	2	0	0	1	109	2	1,8	1	0,9	
18:45 - 19:00	1	0	0	0	0	0	0	0	0	5	102	2	1	0	0	105	3	1	6	102	2	1	0	0	105	3	2,9	1	1,0	

Stundenwerte

7:00 - 8:00	2	10	1	1	0	0	12	2	1
7:15 - 8:15	1	11	1	1	0	0	13	2	1
7:30 - 8:30	1	9	1	1	0	0	11	2	1
7:45 - 8:45	0	7	1	1	0	0	9	2	1
8:00 - 9:00	0	7	2	1	0	0	10	3	1
15:00 - 16:00	4	5	2	2	0	0	9	4	2
15:15 - 16:15	5	3	3	2	0	0	8	5	2
15:30 - 16:30	4	8	3	2	0	0	13	5	2
15:45 - 16:45	4	8	3	2	0	0	13	5	2
16:00 - 17:00	3	8	2	0	0	0	10	2	0
16:15 - 17:15	2	9	0	1	0	0	10	1	1
16:30 - 17:30	2	6	0	1	0	0	7	1	1
16:45 - 17:45	2	6	0	1	0	0	7	1	1
17:00 - 18:00	0	4	0	1	0	0	5	1	1
17:15 - 18:15	1	4	0	0	0	0	4	0	0
17:30 - 18:30	1	2	0	0	0	0	2	0	0
17:45 - 18:45	1	2	0	0	0	0	2	0	0
18:00 - 19:00	2	2	0	0	0	0	2	0	0

Stundenwerte

7:00 - 8:00	45	334	15	1	0	5	355	16	6
7:15 - 8:15	43	343	13	1	0	5	362	14	6
7:30 - 8:30	34	335	14	0	0	5	354	14	5
7:45 - 8:45	18	311	13	0	0	6	330	13	6
8:00 - 9:00	11	249	12	0	0	5	266	12	5
15:00 - 16:00	7	364	6	0	0	5	375	6	5
15:15 - 16:15	12	389	4	0	0	5	398	4	5
15:30 - 16:30	15	456	5	0	0	5	466	5	5
15:45 - 16:45	23	467	7	0	0	6	480	7	6
16:00 - 17:00	22	519	11	0	0	5	535	11	5
16:15 - 17:15	16	533	13	2	0	5	553	15	7
16:30 - 17:30	16	522	13	2	0	5	542	15	7
16:45 - 17:45	9	517	12	2	0	4	535	14	6
17:00 - 18:00	10	464	10	2	0	4	480	12	6
17:15 - 18:15	19	437	9	0	0	4	450	9	4
17:30 - 18:30	28	394	8	0	0	4	406	8	4
17:45 - 18:45	27	391	8	0	0	4	403	8	4
18:00 - 19:00	30	393	7	1	0	4	405	8	5

Stundenwerte

7:00 - 8:00	47	344	16	2	0	5	367	18	5	7	1,9
7:15 - 8:15	44	354	14	2	0	5	375	16	4,3	7	1,9
7:30 - 8:30	35	344	15	1	0	5	365	16	4,4	6	1,6
7:45 - 8:45	18	318	14	1	0	6	339	15	4,4	7	2,1
8:00 - 9:00	11	256	14	1	0	5	276	15	5,4	6	2,2
15:00 - 16:00	11	369	8	2	0	5	384	10	2,6	7	1,8
15:15 - 16:15	17	392	7	2	0	5	406	9	2,2	7	1,7
15:30 - 16:30	19	464	8	2	0	5	479	10	2,1	7	1,5
15:45 - 16:45	27	475	10	2	0	6	493	12	2,4	8	1,6
16:00 - 17:00	25	527	13	0	0	5	545	13	2,4	5	0,9
16:15 - 17:15	18	542	13	3	0	5	563	16	2,8	8	1,4
16:30 - 17:30	18	528	13	3	0	5	549	16	2,9	8	1,5
16:45 - 17:45	11	523	12	3	0	4	542	15	2,8	7	1,3
17:00 - 18:00	10	468	10	3	0	4	485	13	2,7	7	1,4
17:15 - 18:15	20	441	9	0	0	4	454	9	2,0	4	0,9
17:30 - 18:30	29	396	8	0	0	4	408	8	2,0	4	1,0
17:45 - 18:45	28	393	8	0	0	4	405	8	2,0	4	1,0
18:00 - 19:00	32	395	7	1	0	4	407	8	2,0	5	1,2

Zufahrt B - Blatt 1
Am Bahnhof

Zufahrt B - Blatt 2
Am Bahnhof

von B nach A
Am Bahnhof --> Meindorfer Straße - L 16 West

von B nach D
Am Bahnhof --> Meindorfer Straße - L 16 Ost

Summe in der Zufahrt

Zeit von - bis	Zufahrt B - Blatt 1										Zufahrt B - Blatt 2										Summe in der Zufahrt							
	Rad	Pkw/Krad	Lw	Lkw	Lz	Bus	Σ Kfz	Σ GV	Σ SV	Rad	Pkw/Krad	Lw	Lkw	Lz	Bus	Σ Kfz	Σ GV	Σ SV	Rad	Pkw/Krad	Lw	Lkw	Lz	Bus	Σ Kfz	Σ GV	GV [%]	Σ SV
7:00 - 7:15	0	1	2	0	0	0	3	2	0	0	3	2	0	0	0	7	4	2	0	1	4	4	0	10	6	60,0	2	20,0
7:15 - 7:30	0	0	1	1	0	0	2	2	1	0	2	1	2	1	0	6	4	3	0	1	2	3	1	8	6	75,0	4	50,0
7:30 - 7:45	0	2	1	1	0	0	4	2	1	0	4	2	1	0	0	3	2	1	0	0	2	2	0	7	4	57,1	2	28,6
7:45 - 8:00	0	1	1	0	0	0	2	1	0	0	2	1	1	1	0	8	7	2	0	0	1	1	0	10	8	80,0	2	20,0
8:00 - 8:15	0	2	0	1	0	0	3	1	1	0	3	1	3	0	0	5	4	3	0	0	0	0	0	8	5	62,5	4	50,0
8:15 - 8:30	0	3	0	0	0	0	3	0	0	0	3	0	1	0	0	7	1	1	0	0	0	0	0	10	1	10,0	1	10,0
8:30 - 8:45	0	1	0	0	0	0	1	0	0	0	1	0	1	0	0	8	3	1	0	0	0	0	0	9	3	33,3	1	11,1
8:45 - 9:00	0	3	0	0	0	0	3	0	0	0	3	0	1	0	0	6	4	1	0	0	0	0	0	9	4	44,4	1	11,1
15:00 - 15:15	1	2	1	0	0	0	3	1	0	0	3	1	2	0	0	10	3	2	0	0	0	0	0	13	4	30,8	2	15,4
15:15 - 15:30	0	5	0	0	0	0	5	0	0	0	5	0	2	0	0	5	3	2	0	0	0	0	0	10	3	30,0	2	20,0
15:30 - 15:45	0	3	0	0	0	0	3	0	0	0	3	0	2	0	0	7	2	2	0	0	0	0	0	10	2	20,0	2	20,0
15:45 - 16:00	0	6	2	0	0	0	8	2	0	0	8	2	0	0	0	7	0	0	0	0	0	0	0	15	2	13,3	0	0,0
16:00 - 16:15	0	1	0	0	0	0	1	0	0	0	1	0	0	0	0	15	2	0	0	0	0	0	0	16	2	12,5	0	0,0
16:15 - 16:30	0	3	0	1	0	0	4	1	1	0	4	1	1	0	0	15	3	1	0	0	0	0	0	19	4	21,1	2	10,5
16:30 - 16:45	0	8	0	1	0	0	9	1	1	0	9	1	0	0	0	14	1	0	0	0	0	0	0	23	2	8,7	1	4,3
16:45 - 17:00	1	7	0	0	0	0	7	0	0	0	7	0	0	0	0	13	2	0	0	0	0	0	0	20	2	10,0	0	0,0
17:00 - 17:15	0	4	0	0	0	0	4	0	0	0	4	0	0	0	0	16	1	0	0	0	0	0	0	20	1	5,0	0	0,0
17:15 - 17:30	2	7	0	0	0	0	7	0	0	0	7	0	0	0	0	10	1	0	0	0	0	0	0	17	1	5,9	0	0,0
17:30 - 17:45	2	2	0	0	0	0	2	0	0	0	2	0	0	0	0	10	1	0	0	0	0	0	0	12	1	8,3	0	0,0
17:45 - 18:00	0	5	0	0	0	0	5	0	0	0	5	0	1	0	0	8	1	1	0	0	0	0	0	13	1	7,7	1	7,7
18:00 - 18:15	4	1	0	0	0	0	1	0	0	0	1	0	0	0	0	1	0	0	0	0	0	0	0	2	0	0,0	0	0,0
18:15 - 18:30	0	4	1	0	0	0	5	1	0	0	5	1	0	0	0	3	0	0	0	0	0	0	0	8	1	12,5	0	0,0
18:30 - 18:45	0	2	0	0	0	0	2	0	0	0	2	0	3	0	0	11	5	3	0	0	0	0	0	13	5	38,5	3	23,1
18:45 - 19:00	1	0	0	0	0	0	0	0	0	0	0	0	0	0	0	4	0	0	0	0	0	0	0	4	0	0,0	0	0,0

7:00 - 8:00	Stundenwerte										Stundenwerte										Stundenwerte							
	Rad	Pkw/Krad	Lw	Lkw	Lz	Bus	Σ Kfz	Σ GV	Σ SV	Rad	Pkw/Krad	Lw	Lkw	Lz	Bus	Σ Kfz	Σ GV	Σ SV	Rad	Pkw/Krad	Lw	Lkw	Lz	Bus	Σ Kfz	Σ GV	GV [%]	Σ SV
7:00 - 8:00	0	4	5	2	0	0	11	7	2	0	7	9	6	2	0	24	17	8	0	0	0	0	0	35	24	68,6	10	28,6
7:15 - 8:15	0	5	3	3	0	0	11	6	3	0	11	6	7	2	0	22	17	9	0	0	0	0	0	33	23	69,7	12	36,4
7:30 - 8:30	0	8	2	2	0	0	12	4	2	0	12	4	6	1	0	23	14	7	0	0	0	0	0	35	18	51,4	9	25,7
7:45 - 8:45	0	7	1	1	0	0	9	2	1	0	9	2	1	0	0	28	15	7	0	0	0	0	0	37	17	45,9	8	21,6
8:00 - 9:00	0	9	0	1	0	0	10	1	1	0	10	1	6	0	0	26	12	6	0	0	0	0	0	36	13	36,1	7	19,4
15:00 - 16:00	1	16	3	0	0	0	19	3	0	0	19	3	2	0	0	29	8	6	0	0	0	0	0	48	11	22,9	6	12,5
15:15 - 16:15	0	15	2	0	0	0	17	2	0	0	17	2	4	0	0	34	7	4	0	0	0	0	0	51	9	17,6	4	7,8
15:30 - 16:30	0	13	2	1	0	0	16	3	1	0	16	3	3	0	0	44	7	3	0	0	0	0	0	60	10	16,7	4	6,7
15:45 - 16:45	0	18	2	2	0	0	22	4	2	0	22	4	1	0	0	51	6	1	0	0	0	0	0	73	10	13,7	3	4,1
16:00 - 17:00	1	19	0	2	0	0	21	2	2	0	21	2	1	0	0	57	8	1	0	0	0	0	0	78	10	12,8	3	3,8
16:15 - 17:15	1	22	0	2	0	0	24	2	2	0	24	2	1	0	0	58	7	1	0	0	0	0	0	82	9	11,0	3	3,7
16:30 - 17:30	3	26	0	1	0	0	27	1	1	0	27	1	0	0	0	53	5	0	0	0	0	0	0	80	6	7,5	1	1,3
16:45 - 17:45	5	20	0	0	0	0	20	0	0	0	20	0	0	0	0	49	5	0	0	0	0	0	0	69	5	7,2	0	0,0
17:00 - 18:00	4	18	0	0	0	0	18	0	0	0	18	0	1	0	0	44	4	1	0	0	0	0	0	62	4	6,5	1	1,6
17:15 - 18:15	8	15	0	0	0	0	15	0	0	0	15	0	0	1	0	29	3	1	0	0	0	0	0	44	3	6,8	1	2,3
17:30 - 18:30	6	12	1	0	0	0	13	1	0	0	13	1	0	1	0	22	2	1	0	0	0	0	0	35	3	8,6	1	2,9
17:45 - 18:45	4	12	1	0	0	0	13	1	0	0	13	1	3	1	0	23	6	4	0	0	0	0	0	36	7	19,4	4	11,1
18:00 - 19:00	5	7	1	0	0	0	8	1	0	0	8	1	0	0	0	19	5	3	0	0	0	0	0	27	6	22,2	3	11,1

Zufahrt D - Blatt 1
Meindorfer Straße - L 16 Ost

Zeit von - bis	von D nach A Meindorfer Straße - L 16 Ost --> Meindorfer Straße - L 16 West									von D nach B Meindorfer Straße - L 16 Ost --> Am Bahnhof									Summe in der Zufahrt										
	Rad	Pkw/Krad	Lw	Lkw	Lz	Bus	Σ Kfz	Σ GV	Σ SV	Rad	Pkw/Krad	Lw	Lkw	Lz	Bus	Σ Kfz	Σ GV	Σ SV	Rad	Pkw/Krad	Lw	Lkw	Lz	Bus	Σ Kfz	Σ GV	GV [%]	Σ SV	SV [%]
7:00 - 7:15	1	94	7	0	0	3	104	7	3	2	5	1	1	0	0	7	2	1	3	99	8	1	0	3	111	9	8,1	4	3,6
7:15 - 7:30	4	97	4	0	0	1	102	4	1	0	7	4	0	0	0	11	4	0	0	104	8	0	0	1	113	8	7,1	1	0,9
7:30 - 7:45	2	130	8	1	0	2	141	9	3	0	8	1	0	0	0	9	1	0	0	138	9	1	0	2	150	10	6,7	3	2,0
7:45 - 8:00	1	107	3	0	0	3	113	3	3	0	6	0	1	0	0	7	1	1	1	113	3	1	1	3	120	4	3,3	4	3,3
8:00 - 8:15	2	103	3	2	0	1	109	5	3	0	7	0	1	1	0	9	2	2	2	110	3	3	1	1	118	7	5,9	5	4,2
8:15 - 8:30	4	102	5	1	0	0	108	6	1	0	7	2	1	0	0	10	3	1	1	109	7	2	0	0	118	9	7,6	2	1,7
8:30 - 8:45	0	71	10	1	0	1	83	11	2	0	4	0	2	0	0	6	2	2	2	75	10	3	1	1	89	13	14,6	4	4,5
8:45 - 9:00	6	62	4	0	0	2	68	4	2	0	4	1	0	0	0	5	1	0	0	66	5	0	0	2	73	5	6,8	2	2,7
15:00 - 15:15	11	72	0	0	0	1	73	0	1	0	3	2	0	1	0	6	3	1	1	75	2	0	1	1	79	3	3,8	2	2,5
15:15 - 15:30	3	65	3	0	0	1	69	3	1	0	8	2	2	0	0	12	4	2	2	73	5	2	0	1	81	7	8,6	3	3,7
15:30 - 15:45	7	71	4	0	0	1	76	4	1	1	1	1	1	1	0	4	3	2	2	72	5	1	1	1	80	7	8,8	3	3,8
15:45 - 16:00	5	78	5	1	0	2	86	6	3	0	6	1	2	0	0	9	3	2	2	84	6	3	0	2	95	9	9,5	5	5,3
16:00 - 16:15	3	105	3	0	0	1	109	3	1	0	7	4	1	0	0	12	5	1	1	112	7	1	0	1	121	8	6,6	2	1,7
16:15 - 16:30	3	89	4	1	0	1	95	5	2	0	1	3	1	0	0	5	4	1	1	90	7	2	0	1	100	9	9,0	3	3,0
16:30 - 16:45	4	108	2	1	0	1	112	3	2	0	6	1	1	2	0	10	4	3	3	114	3	2	2	1	122	7	5,7	5	4,1
16:45 - 17:00	8	103	5	0	0	2	110	5	2	0	3	1	0	0	0	4	1	0	0	106	6	0	0	2	114	6	5,3	2	1,8
17:00 - 17:15	4	87	3	0	0	1	91	3	1	0	8	1	0	2	0	11	3	2	2	95	4	0	0	1	102	6	5,9	3	2,9
17:15 - 17:30	4	97	3	1	0	0	101	4	1	0	2	0	0	0	0	2	0	0	0	99	3	1	0	0	103	4	3,9	1	1,0
17:30 - 17:45	8	104	2	0	0	1	107	2	1	0	2	1	1	0	0	4	2	1	1	106	3	1	0	1	111	4	3,6	2	1,8
17:45 - 18:00	3	75	2	0	0	2	79	2	2	0	5	0	0	0	0	5	0	0	0	80	2	0	0	2	84	2	2,4	2	2,4
18:00 - 18:15	5	105	3	0	0	1	109	3	1	0	3	1	0	0	0	4	1	0	0	108	4	0	0	1	113	4	3,5	1	0,9
18:15 - 18:30	7	73	3	0	0	0	76	3	0	0	3	0	1	0	0	4	1	1	1	76	3	1	0	0	80	4	5,0	1	1,3
18:30 - 18:45	1	80	1	0	0	1	82	1	1	0	4	0	0	0	0	4	0	0	0	84	1	0	0	1	86	1	1,2	1	1,2
18:45 - 19:00	7	61	2	0	0	2	65	2	2	0	6	0	0	1	0	7	1	1	1	67	2	0	1	2	72	3	4,2	3	4,2

7:00 - 8:00	Stundenwerte									Stundenwerte									Stundenwerte										
	8	428	22	1	0	9	460	23	10	2	26	6	2	0	0	34	8	2	10	454	28	3	0	9	494	31	6,3	12	2,4
7:15 - 8:15	9	437	18	3	0	7	465	21	10	0	28	5	2	1	0	36	8	3	9	465	23	5	1	7	501	29	5,8	13	2,6
7:30 - 8:30	9	442	19	4	0	6	471	23	10	0	28	3	3	1	0	35	7	4	9	470	22	7	1	6	506	30	5,9	14	2,8
7:45 - 8:45	7	383	21	4	0	5	413	25	9	0	24	2	5	1	0	32	8	6	7	407	23	9	1	5	445	33	7,4	15	3,4
8:00 - 9:00	12	338	22	4	0	4	368	26	8	0	22	3	4	1	0	30	8	5	12	360	25	8	1	4	398	34	8,5	13	3,3
15:00 - 16:00	26	286	12	1	0	5	304	13	6	1	18	6	5	2	0	31	13	7	27	304	18	6	2	5	335	26	7,8	13	3,9
15:15 - 16:15	18	319	15	1	0	5	340	16	6	1	22	8	6	1	0	37	15	7	19	341	23	7	1	5	377	31	8,2	13	3,4
15:30 - 16:30	18	343	16	2	0	5	366	18	7	1	15	9	5	1	0	30	15	6	19	358	25	7	1	5	396	33	8,3	13	3,3
15:45 - 16:45	15	380	14	3	0	5	402	17	8	0	20	9	5	2	0	36	16	7	15	400	23	8	2	5	438	33	7,5	15	3,4
16:00 - 17:00	18	405	14	2	0	5	426	16	7	0	17	9	3	2	0	31	14	5	18	422	23	5	2	5	457	30	6,6	12	2,6
16:15 - 17:15	19	387	14	2	0	5	408	16	7	0	18	6	2	4	0	30	12	6	19	405	20	4	4	5	438	28	6,4	13	3,0
16:30 - 17:30	20	395	13	2	0	4	414	15	6	0	19	3	1	4	0	27	8	5	20	414	16	3	4	4	441	23	5,2	11	2,5
16:45 - 17:45	24	391	13	1	0	4	409	14	5	0	15	3	1	2	0	21	6	3	24	406	16	2	2	4	430	20	4,7	8	1,9
17:00 - 18:00	19	363	10	1	0	4	378	11	5	0	17	2	1	2	0	22	5	3	19	380	12	2	2	4	400	16	4,0	8	2,0
17:15 - 18:15	20	381	10	1	0	4	396	11	5	0	12	2	1	0	0	15	3	1	20	393	12	2	0	4	411	14	3,4	6	1,5
17:30 - 18:30	23	357	10	0	0	4	371	10	4	0	13	2	2	0	0	17	4	2	23	370	12	2	0	4	388	14	3,6	6	1,5
17:45 - 18:45	16	333	9	0	0	4	346	9	4	0	15	1	1	0	0	17	2	1	16	348	10	1	0	4	363	11	3,0	5	1,4
18:00 - 19:00	20	319	9	0	0	4	332	9	4	0	16	1	1	1	0	19	3	2	20	335	10	1	1	4	351	12	3,4	6	1,7